

MANISCOPIC

MLT 845 - 120 LSU

- Lifting height : 7.55 m
- Capacity : 4500 kg
- Maximum forward reach : 4.57 m
- Torque convertor
- 4 wheel-drive
- Engine : 123 HP
- Load Sensing Ultra : 150 l/mn - 240 bars

LOAD SENSING ULTRA



MLT 845 - 120 LSU - TFF 45 MT 1040



MLT 845 - 120 LSU

Lift capacity4500 kg
 at 500 mm from forks heels
 Tipping load
 at maximum reach1610 kg
 Tear out force with toothed digging bucket
 to ISO 8313 with tilting ram6650 daN

Lift height7.55 m
Times : unladen/loaded (in s)
 Lifting.....9.6/10.4
 Lowering.....6.1/5.6
 Boom extension.....9.8/10.1
 Boom retraction.....7.8/7.9
 Time unladen (in s)
 Crowd3.7
 Dump.....3.2

Tyres
 445/70 R 24

Forks (mm)
 Length1200
 Width x thickness.....125 x 40
 Maximum distance between forks.....1260
 Carriage rotation142°

Multidisc brakes hydraulically assisted on both axles

Perkins engine
 Turbo : 1104 C - 44 TA4 cylindres 4400 cm³
 Power (ISO TR 14396).....123 HP/90.5 kw
 Maximum torque.....434 Nm at 1400 rpm
 Direct injection
 Water cooling

TransmissionTorque convertor
 Electro - hydraulic reversing shift
 4 speeds forward and reverse
 Maximum travel speed25 km/h*

Turbo 120 LSU :150 l./mn - 270 bars
 Load Sensing pump with electronic control
 Electro proportional command monolever
 Flow divider with load sensing device driving and braking

Capacities
 Cooling system18.5 l.
 Engine oil 11 l.
 Hydraulic oil131 l.
 Transmission oil.....16 l.
 Fuel tank.....135 l.

Weight unladen (with forks)8285 kg
Overall width.....2.39 m
Overall height2.56 m
Turning radius (outside wheels).....4.15 m
Overall length5.22 m
Ground clearance0.44 m
Drawbar pull9000 daN

Reach at maximum height : 1.46 m

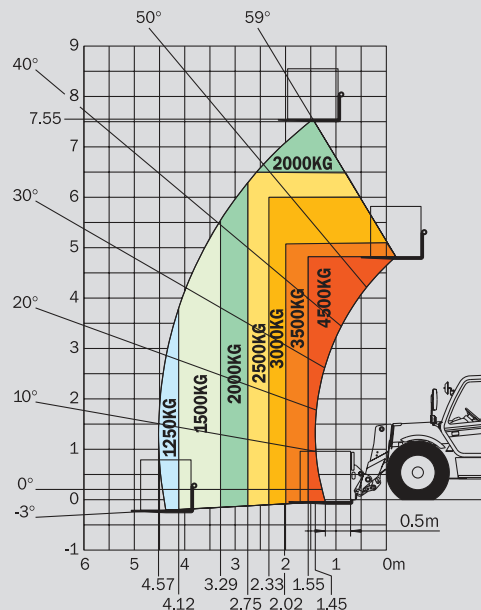

Under
 EN 1459
 annexe B

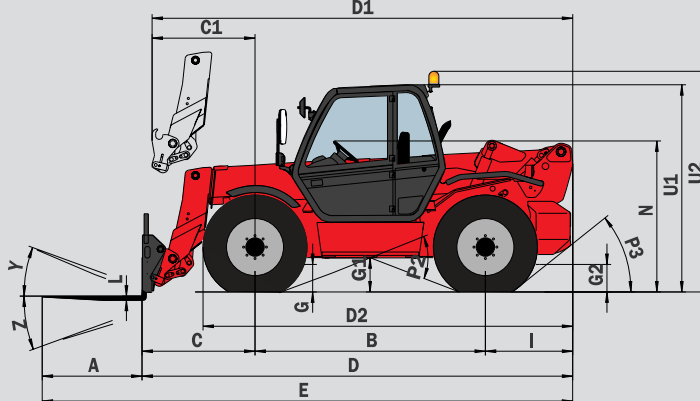

MLT 845 - 120 LSU

A	1200
B	2770
C	1409
C1	1487
D	5229
D1	5307
D2	4395
E	6429
F	1950
F1	1950
G	440
G1	435
G2	440
I	1050
J	950
K	1260
L	50
N	1850/1900
O	125
P2	43.5°
P3	40°
R	3930
S	8146
T	3703
U1	2565
U2	2745
V	5173
V1	1470
V2	4153
W	2395
Y	12°
Z	130°

mm

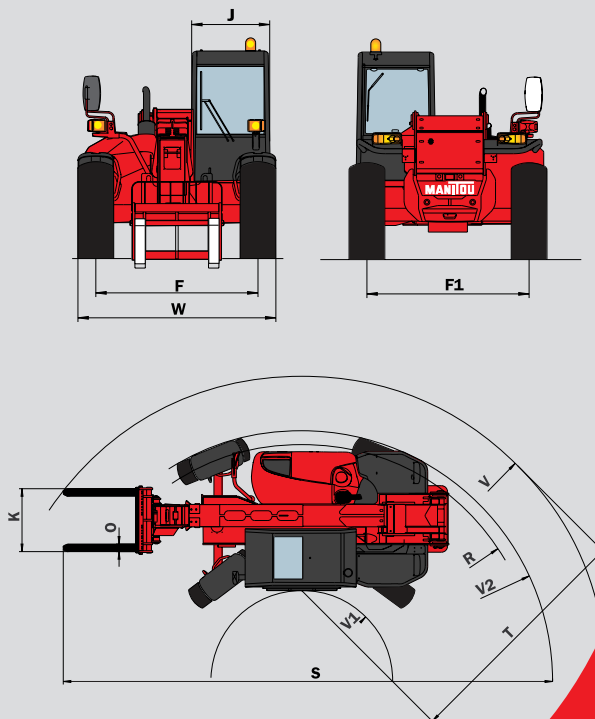

This publication in no way constitutes an offer and the company reserves the right to alter specification without prior notice.
 The MANITOU models presented in this brochure can be supplied complete with optional equipment attachments.
 PATENTS FR 93 14367 - EP 0 656 315 - US PENDING

