

SL 380 Midi
– Compact and reliable

SL 380 Midi
for indoor use



Midi – for lifting medium-sized items

The SL 380 Midi fills the gap in the market between the Standard and Maxi models. The SL 380 Midi handles everything in between.

- Two vacuum circuits with two pumps
- Four Suction pads Ø 300 mm
- Multifunctional
- Self-propelled
- Labour-saving
- Improves work environment
- Tried-and-tested Danish quality

This Smartlift has a dual-circuit vacuum system for maximum safety. Vacuum circuits shown here with blue and red vacuum tubes.

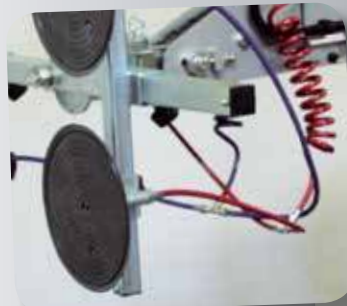

The SL 380 Midi is small and smart, but still strong and powerful.



The SL 380 Midi is equipped with the most reliable suction cups on the market.

N.A. Christensensvej 39
DK-7900 Nykøbing Mors
Tel.: +45 97 72 29 11
E-mail: smart@smartlift.dk
www.smartlift.dk

Smart Lift
DENMARK

The Smartlift is easily transported in a van or on a trailer



The SL 380 Midi can be shifted sideways up to 100 mm for precision adjustment during the window installation process.



The SL 380 Midi is fitted for window and glass installation as standard, but can be supplied with a special device for lifting, e.g. heavy fire doors and gates.

Technical data

Description	Value
Weight	570 kg
Height	1350 mm
Width (min)	650 mm
Length (min)	1820 mm
Extension of arm	500 mm
Tip from horizontal	45° back / 105° forward
Sideshift	100 mm
Charging voltage	230 volt
Integrated charger	Cetek XT 14000
Charging time	Approx 8 hours
Battery (2 x 12v) 24 volt	2 x 60 A
Running period	Approx 30 hours
Rear-wheel drive	700 Watt
Suction pads	4 unit Ø 300 mm

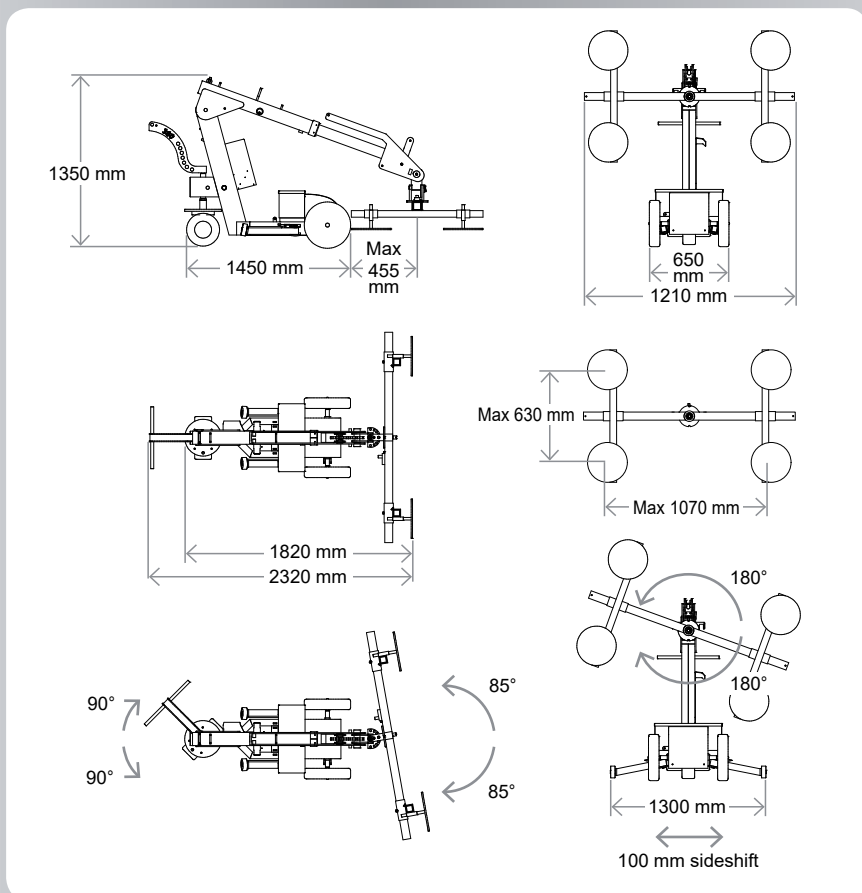
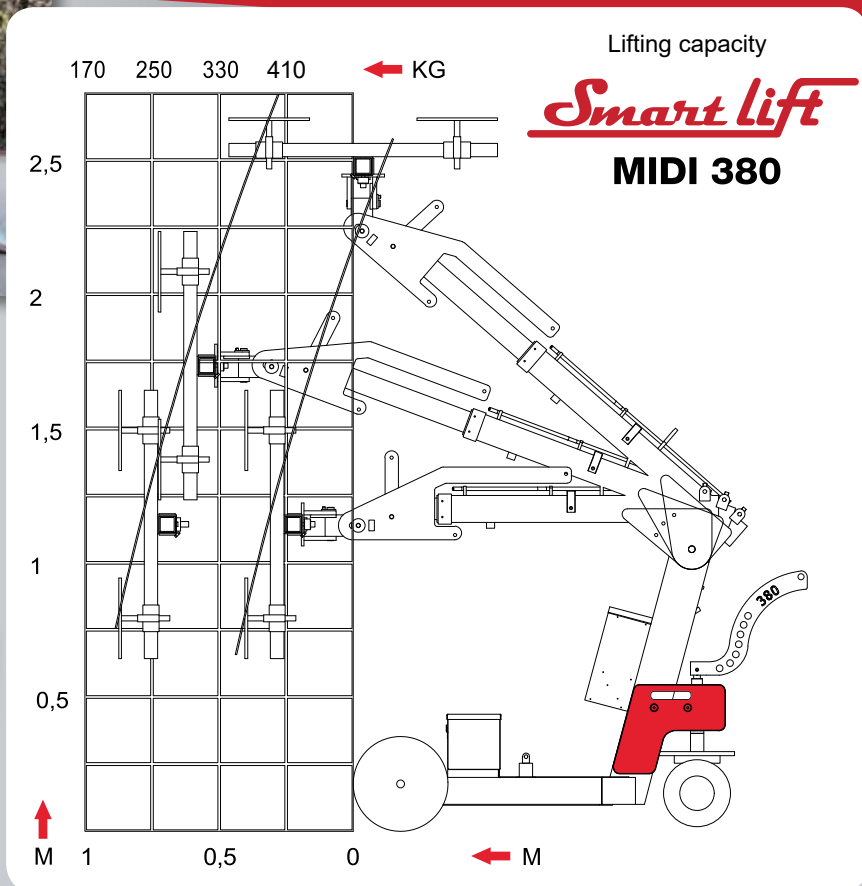

N.A. Christensensvej 39
 DK-7900 Nykøbing Mors
 Tel.: +45 97 72 29 11
 E-mail: smart@smartlift.dk
 www.smartlift.dk