



5000 Kg



3050x1200x1750



9,5 m



6,2 m



Radio Remote Control

- Large display
- Two batteries
- Joystick
- Crane and wheel control

Modular Flying JIB

Two modular sections JIB, with tilting head. Pulley mode or hook mode

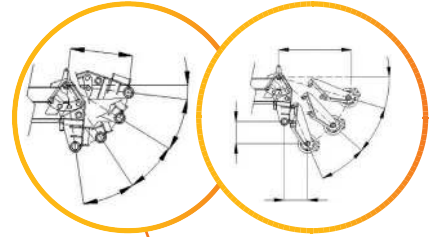

Hydraulic Winch

- 1.000 Kg capacity
- 60 mt wire rope



PATENTED

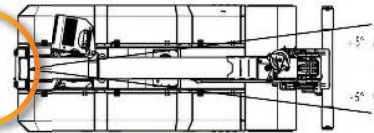

Boom Rotation

Innovative boom rotation system + 5° / - 5°

- 5° / + 5°
Rotation

Electronic LMI

- Load and moment indicator
- Plug & Play
- Diagnostic troubleshooting
- Full safety respect EN13000

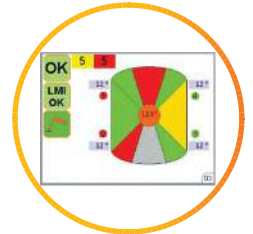

Rechargeable Batteries

Long lasting rechargeable batteries 48 V 620 Ah



Frontal Traction

Frontal hydraulic traction for a perfect grip, powerful in any condition



Frontal Stabilizer

Increasing stability and lifting capacity



Crane Options

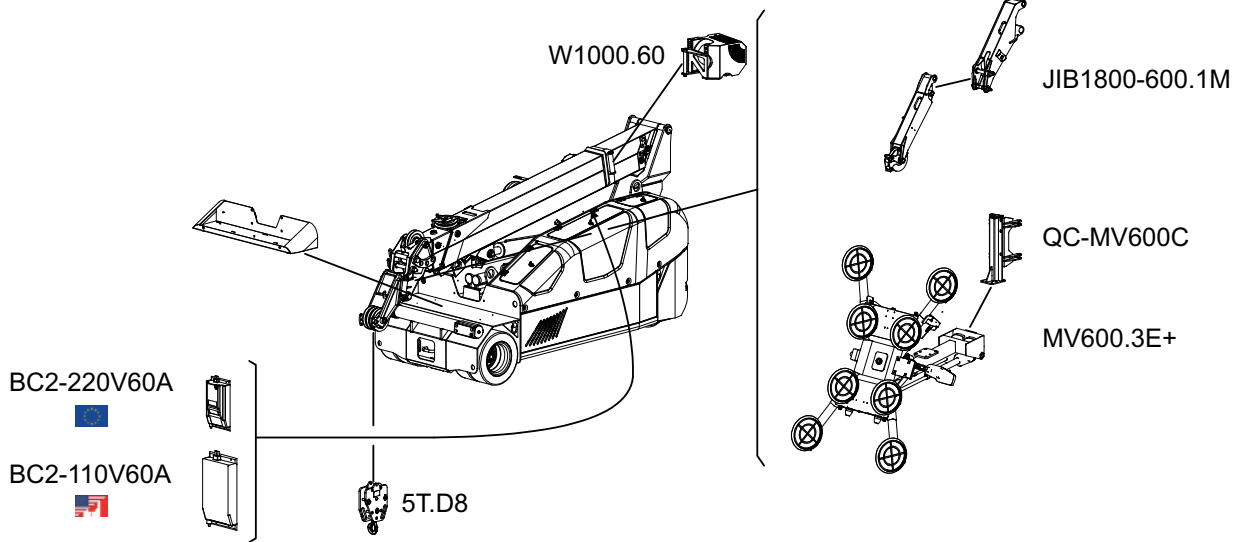

Load Chart

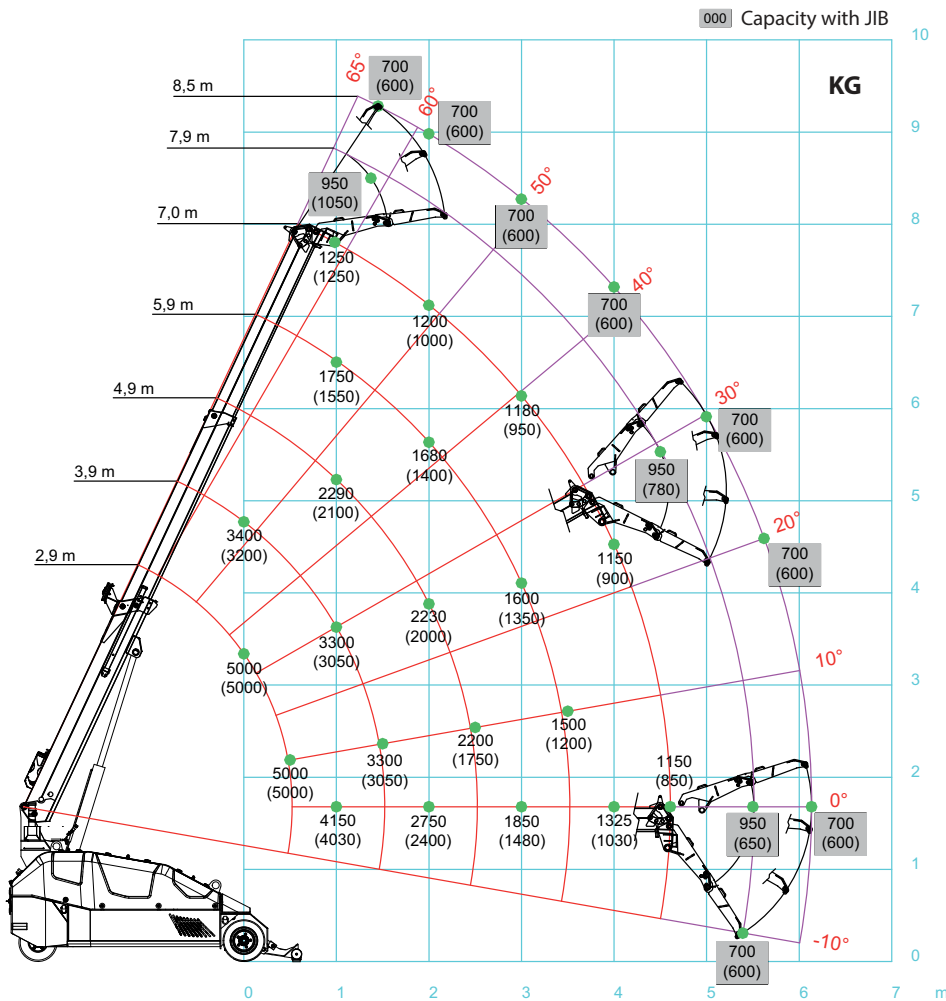

Technical Info

	3050x1200x1750 mm		
	kg		
	MPK50	3450	
	/	1000	
	5T-D8	10	
	JIB1800-700.2M	50	
	4 Km/h		
	20%		
	1000 kg		
	60 m - Ø 8 mm		
	20 m/min		
	n°2 24V	kW	12,0 kW
	48 Ah		