TECHNICAL DATA SHEET

MT 420 H NEW BUGGY

Manitou Telescopic



MT 420 H NEW BUGGY

MT420 H New Buggy	
Lifting	
Max. capacity	2000 kg
Max. lifting height	4.30 m
Break-out force with bucket (ISO 8313)	1886 daN
Tyres	
12-16.5 12PR SKS CL TUBELESS	
Braking	
Service brake	Disc brake on the cardan shaft
Parking brake	Automatic Negative Handbrake
Unladen time	
Lifting	5.0 s
Lowering	3.5 s
Extension	4.8 s
Retraction	3.0 s
Crowd	3.3 s
Dump	2.7 s
Engine	
KUBOTA STAGE III A	
Type	V2607-DI-E3B
Cubic capacity	4 cylinders - 2615 cm ³
Power	49 hp/36 kW
Max. torque	170 Nm at 1600 rpm
Injection	direct
Cooling	water
Laden drawbar pull	2850 daN
Transmission	
hydrostatic	
Reversing shift	electro-hydraulic
Number of gears (forward/reverse)	2/2
Drive wheels	4 wheel drive
Steering mode	4 wheel steer - 3 Steering Modes
Max. travel speed (may vary according to applicable regulations)	25 kph
Controls	
JSM® Joystick multi - function Load Limiter Cut off system - EN15000 Norm	
Hydraulics	
Pump	gear type 65 l/min – 235 bar
Capacities	
Cooling system	8.6 l
Oil engine	10.2 l
Hydraulic oil	70 l
Fuel	60 l
Unladen weight (with forks)	4260 kg
Dimensions	
C. Front wheel centre to carriage	1.03 m
B. Wheelbase	2.13 m
I. Rear wheel centre to rear face	0.47 m
D. Overall length to carriage	3.63 m
G1. Ground clearance	0.24 m
J. Overall width of cab	0.79 m
F. Inside tyre width	1.17 m
W Overall width	1.49 m
U2. Overall height	1.90 m
Y Crowd angle	12°
Z Dump angle	116°
Standard forks (length x width x thickness)	1200 x 100 x 40 mm
Turning radius (over tyres)	2.98 m
Noise and vibration	
Noise at driving position (LpA)	76 dB
Environmental noise (LwA)	104 dB
Vibration to whole hand/arm	<2.50 m/s ²

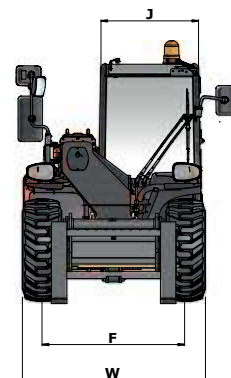
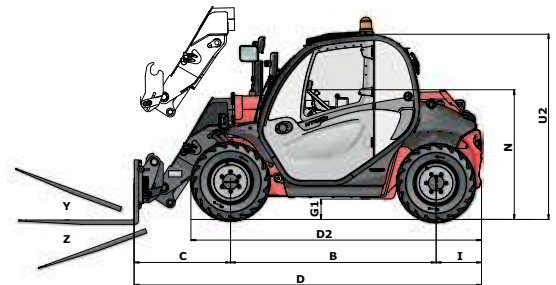
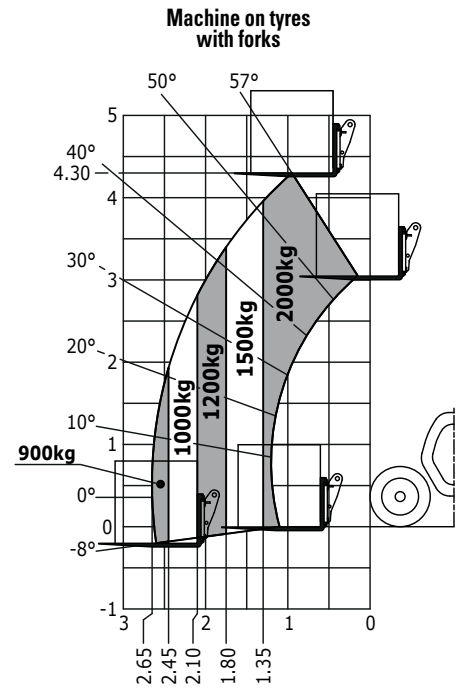

This brochure describes versions and configuration options for Manitou products which may be fitted with different equipment. The equipment described in this brochure may be standard, optional or not available depending on version. Manitou reserves the right to change the specifications shown and described at any time and without prior warning. The manufacturer is not liable for the specifications given. For more information, contact your Manitou dealer. Non-contractual document. Product descriptions may differ from actual products. List of specifications is not comprehensive. The logos and visual identity of the company are the property of Manitou and may not be used without authorisation. All rights reserved. The photos and diagrams contained in this brochure are provided for information only.

MANITOU BF SA - Limited company with board of directors - Share capital: 39,547,824 euros - 857 802 508 RCS Nantes

