

ALMACRAWLER



MULTI-LOADER 2.5

Translation of original instructions



Prior to commissioning the machine carefully read this Use and Maintenance Manual

Note: table of contents at the end of the manual

Edition	Date
00	22/03/2017

1 GENERAL INFORMATION

1.1 Documents supplied with each machine

- CE Declaration of conformity
- Instruction Manual (this manual)
- Spare Parts Manual
- Wiring diagrams and hydraulic layouts
- Report register

1.2 Details of Manual

- Instruction manual
- Model: *MULTI-LOADER 2.5*

Note: Some of the photos and illustrations may not refer specifically to the version of the machine in your possession, but provide indications concerning the purpose for which they have been included.

RECIPIENTS OF THIS MANUAL

- User
- Maintenance technician



Attention: the servicing personnel must be properly trained and experienced.



CAREFULLY READ this manual before performing any operation on the machine.
If in doubt, do not improvise. Call the assistance service.

1.3 Ownership of the information

This document contains confidential information. All rights reserved.

This manual may be neither partially nor totally duplicated without the prior written authorization of ALMAC s.r.l.

This document may only be used by the customer to whom the manual has been supplied along with the machine, and only for the purpose of use and maintenance of the machine to which the manual refers.

ALMAC s.r.l. hereby declares that the information in this manual was congruent with the technical and safety specifications of the machine to which the manual refers. The manufacturer declines all liability for direct or indirect damage to persons, things or animals deriving from use of the machine in conditions differing from those envisaged.

ALMAC s.r.l. reserves the right to make changes or improvements, without prior notice, to the documentary material and to the machines, including marketed machines of the same model as that to which this manual refers but with a different serial number.

The information contained in this manual refers in particular to the equipment specified in "*Identification Data*" and in the related documentation.

1.4 Manufacturer's identification data

ALMAC S.r.l.

e-mail: info@almac-italia.com

Tel. +39 0375 83 35 27

Fax. +39 0375 78 43 50

VAT no. and Tax Code 02559800350

Registered Office
Viale Ruggeri 6/A
42016 - Guastalla (RE) - Italy

Operational Headquarters
Via Caduti sul Lavoro 1
42012 - Viadana (MN) - Italy

1.5 Identification data.

The machine named MULTI-LOADER 2.5 is defined according to the current technical standards such as:

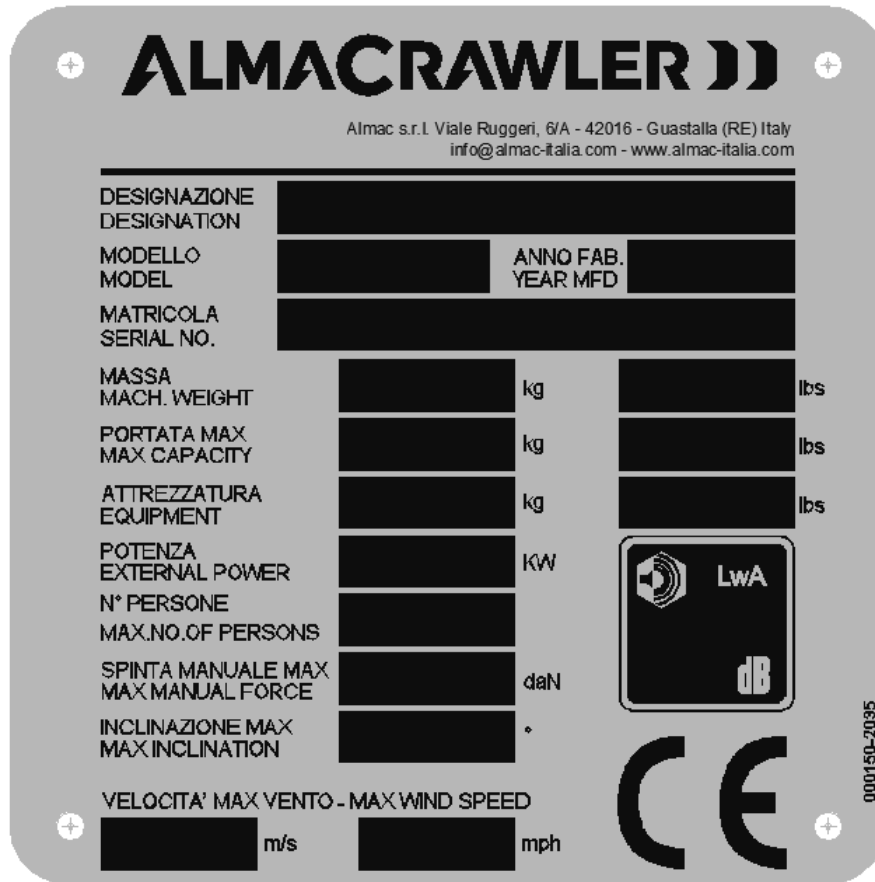

Identification plate

In any case, refer to the data on the identification plate for an exact identification.

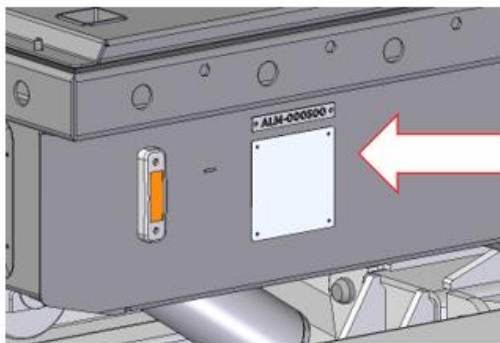

1.6 Performance

Below are the configurations that can be assumed in the work and transportation conditions:

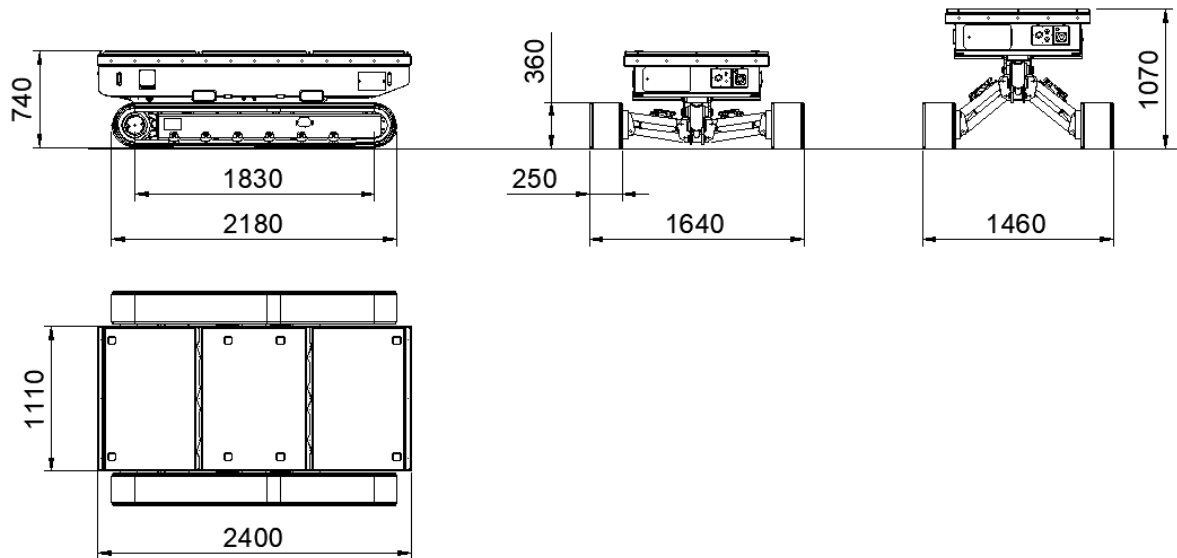

Characteristic dimensions			
Machine length		m	2.40
Maximum width Widened track		m	1.64
Maximum width Narrow track		m	1.46
Height of crawler		mm	360
Width of crawler		mm	250
Load platform minimum height Narrow track		m	1.07
Load platform minimum height Widened track		m	0.74
Load platform width		m	1.11
Load platform length		m	2.40

Technical data		
Maximum capacity	kg	2500
Hydraulic side-shift pressure	bar	220
Maximum capacity	kg	2500
Hydraulic pressure traslation	bar	220
Oil tank capacity	l	35
Climb angle	°	25
Maximum side slope of the terrain	°	14
Maximum longitudinal slope of the terrain	°	20 / 15
Maximum travelling speed	km/h	2.0
Overall weight	kg	1800
Traction battery voltage and capacity	V/Ah	48 / 180
Lead Crystal battery pack		Nr.8 x 180 Ah
Traction battery weight (single cell)	kg	38

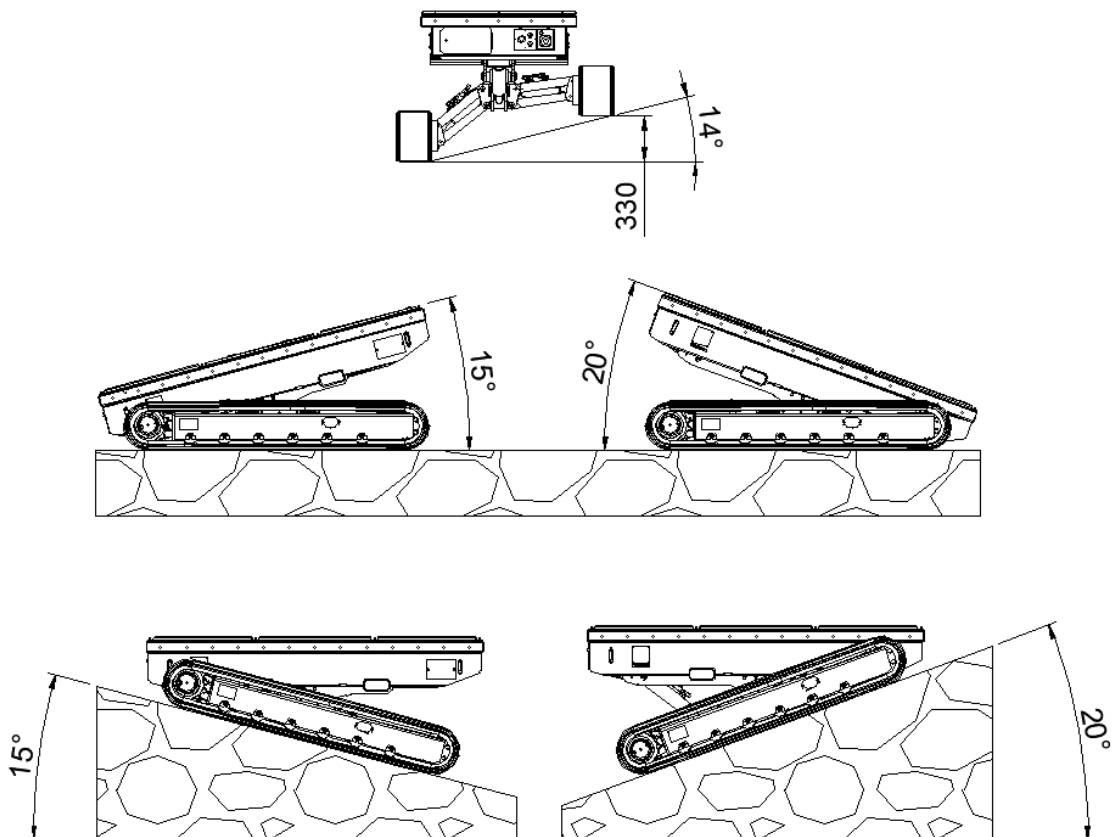

Standard equipment	Optional equipment
Proportional electrohydraulic controls	Electric motor 220V/2.2kw or 110V/1.9kw
Lead Crystal battery pack 180Ah/48V	
Electric motor 48V - 3000W	
Automatic accelerator	
Remote control	
CANBUS display to manage working hours and alarms	
Dual speed gear motors	
Warning buzzer	
Anchorage points for lifting-transportation	
Anchorage points for strap anchoring	
Dynamic levelling system of the machine	
Electronic tilt control	

Engine specifications	Electrical
Dry weight	14 kg
Installed power	3 kW
Rpm	3000
Power supply	48 V

Batteries series technical specifications	
Nominal Capacity [Ah]	180Ah
Nominal voltage [V]	48V (6 x 8)
Number of batteries (Battery series)	8
Maximum End Charge Voltage [V]	55V
Minimum Operational Voltage [V]	45V
Nominal Discharge Current [A]	100 A
Maximum Discharge Current [A]	120 A
Nominal Charge Current [A]	40 A
DOD (Depth of discharge) [%]	80%
Useful Life	≥2000Cycles@80%DOD
Operational Temperatures	-30°C / +55°C *
Operational Temperatures (Discharge)	-30°C / +55°C
Battery Dimensions (L*W*H) [mm]	260 * 180 * 270
Batteries Series Weight [Kg]	264 (33 x 8)

Batteries series technical specifications	
Technology	Lead Crystal Acid

1.7 CE Declaration of Conformity

See facsimile of CE declaration of conformity enclosed with this manual.

The machine described in this manual complies with the following standards:

- Directive 2006/42/EC - Machinery Directive that amends Directive 95/16/EC
- Legislative Decree 17/2010 - Implementation of Machinery Directive 2006/42/EC
- EN ISO 12100:2010 Safety of machinery -General principles for design - Risk assessment and reduction

All parts available on the market and “partly completed machinery” installed on the platform conform to the aforementioned Directives and those that specifically govern the product.

1.8 Warranty

ALMAC S.r.l. guarantees the equipment it manufactures and undertakes to replace, free of charge and within the shortest possible time, those parts that, in its opinion, possess manufacturing and/or material defects.

Work under guarantee must only be performed by workshops authorised by ALMAC S.r.l. and only when the Customer is up to date with the payments.

The Customer will not be entitled to work under guarantee unless he consigns the equipment for repair within 30 days from the date of the first complaint, to be made in writing.

With the exception of fraud or gross negligence, ALMAC S.r.l. is relieved of all liability towards the Customer for damage deriving from flaws/defects in the traded equipment.

The warranty with which the Customer is provided becomes void if modifications are made to the machines without prior written authorization from ALMAC S.r.l. or should the Customer make incorrect/improper use of the machines.

1.8.1 Request for interventions during warranty period and formalities

ALMAC S.r.l. must be notified of requests for spare parts or technical interventions under guarantee as soon as a defect is discovered.

Always indicate the type of machine and its serial number when requesting spare parts under guarantee or technical interventions under guarantee. This information is given on the identification plate of the equipment.

1.9 Assistance

As far as the optimum use of the machine and extraordinary maintenance are concerned, this manual does not replace the expertise of the Technical Assistance sent by ALMAC S.r.l. (refer also to the *Maintenance Chapter*).

1.9.1 Request for assistance and repairs

To request ALMAC S.r.l. specialized Assistance Service, the Customer may contact:

	REGISTERED OFFICE	OPERATIONAL HEADQUARTERS
	ALMAC S.r.l. Viale Ruggeri 6/A 42016 Guastalla (RE) Italy	ALMAC S.r.l. Via Caduti sul lavoro 1 46019 Viadana (MN) Tel. +39 0375 833527 Fax. +39 0375 784350 Mail. info@almac-italia.com

In case of intervention request, specify the machine version and serial number; the data is indicated on the identification plate attached to the machine.

1.10 Use of the manual



Note: Keep this manual in an accessible place known to all users (operators and maintenance workers).

Note: This manual must be kept in a protected place inside the compartment provided on the work platform so that it can be easily accessed for consultation throughout the entire technical life of the machine.

Note: If this manual is lost or damaged, a new copy must be ordered from the manufacturer. Specify the serial number of the machine (given on the relative identification plate) when requesting a new copy of the manual. The manufacturer undertakes to provide a new copy.

Note: When selling used equipment, this manual and the related attachments must be handed and the manufacturer must be informed as regards the new owner (*see Appendix 3 - Transfer of Ownership*)



Read carefully *Chapter 1 General Information, Chapter 2 Safety information, Chapter 3 Description of the Machine and Performance, Chapter 4 Operating instructions, Chapter 5 Emergency Procedures.*

Always consult the relative chapter when using, servicing the machine or when it is demolished.

1.11 Intended use and improper uses

1.11.1 Intended use

The machine described in this manual is a machine designed to transport various materials and/or pieces of equipment.

The maximum allowed capacity for this model is 2500 kg.

The machine was designed and built to be driven exclusively by the remote control console. The control workstation is exclusively on the ground.



Attention: NEVER exceed the machine's established maximum capacity.

Attention: Operation of the machine with operator on the loading platform is FORBIDDEN. The machine MUST only be controlled from the ground via the console.

Attention: It is FORBIDDEN to use the machine to tow other equipment or vehicles.

Warning: the machine is designed to be driven around within public or private areas. It is not designed for road circulation



Warning: The machine IS NOT SET FOR OPERATION IN ATEX CLASSIFIED ATMOSPHERES



If the machine is used in places open to the public or in construction sites where persons may transit or remain in the vicinity, the WORK AREA MUST BE CORDONED OFF in a suitable way (e.g. chains and posts).

1.11.2 Improper uses

Any other use not specifically indicated in *1.11.1 Intended use*.

- It is forbidden to operate the machine from the ground using the mobile push-button panel with an operator on the loading platform.

1.11.3 Cases that relieve the manufacturer from liability

The manufacturer declines all liability in the following cases:

- Use not indicated in this manual;
- Improper use of the machine or its use by untrained personnel;
- Use that fails to comply with the specific standards;
- Insufficient scheduled maintenance;
- Unauthorised modifications or interventions;
- Removal of seals;
- Use of non-original replacement parts;
- Total or partial failure to observe the instructions;
- Failure to perform the Routine Inspections required by the laws in force.

2 SAFETY INFORMATION

2.1 *Fitness of the personnel*

The operators in charge of using the machine must be properly trained, informed, instructed on how to use the machine in safe conditions and must possess a training certificate issued in accordance with the legislation in force at the time of use*.

The operators who use the machine must be over 18 years of age and be recognised as psychophysically fit for the task in question. The following requirements must be ascertained before the operators are allowed to drive the machine:

- sight and hearing in good conditions
- absence of changes induced by use of alcohol or drugs
- psychological equilibrium, absence of depression or stress

Operators who use the machine for professional purposes must undergo health surveillance as required by Legislative decree 81/2008 and successive amendments, particularly with regard to alcohol addiction and alcohol concentration tests.

**The law that currently governs health control and surveillance of workers is the Provision of the State-Regions Permanent Conference of 16 March 2006.*



Note: ALMAC S.r.l. declines all liability for damage to persons, animals and things deriving from:

- failure to comply with the safety regulations
- use of the machine by unqualified operators
- failure to comply with the recommendations in the documentation supplied

2.2 Warnings

The following sign plates are affixed to the machine:

- Identification
- Instructions
- Command/prohibition sign plates
- Caution
- Danger

2.2.1 Plates indicating instructions, obligations, dangers, prohibitions and warnings

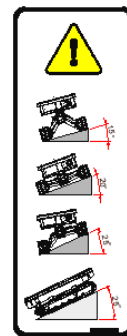
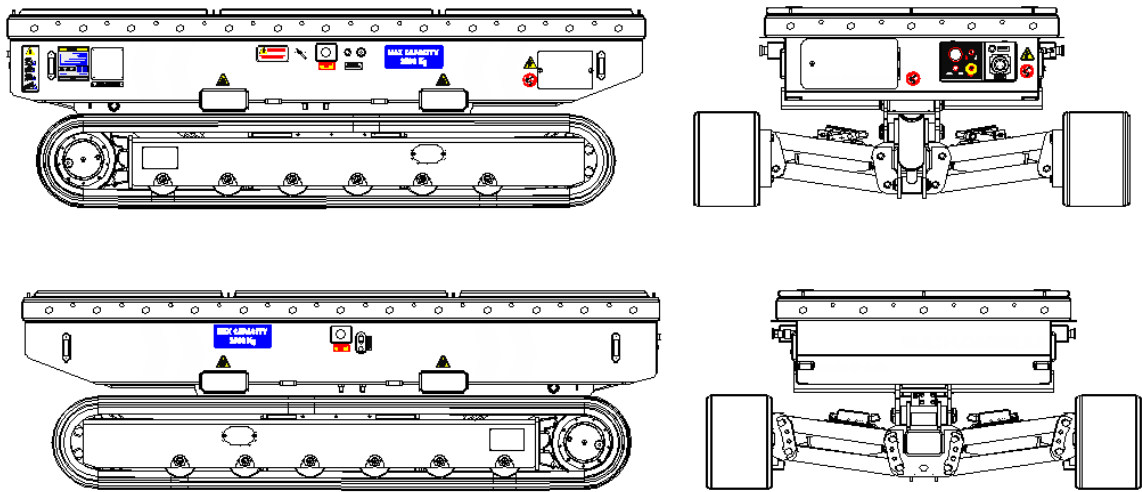

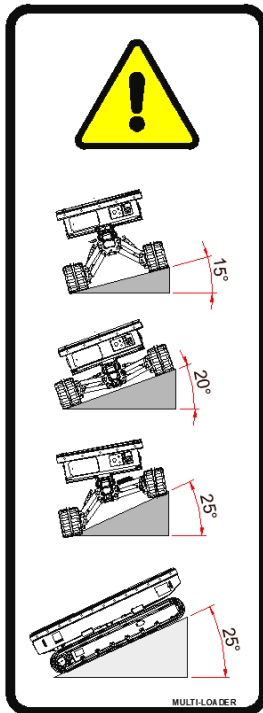
**Maximum inclination of the ground:**

- Front inclination of the ground: The maximum front inclination of the ground to stay safe is 25°. There is no electronic control for this condition, which is at the discretion of the operator.
- Lateral inclination of the ground: The maximum lateral inclination of the ground, keeping the frame as level as possible, to stay safe is 25°. There is no electronic control for this condition, which is at the discretion of the operator.
- Lateral inclination of the ground with a narrow track: The maximum lateral inclination of the ground, with a narrow track, to stay safe is 15°. There is no electronic control for this condition, which is at the discretion of the operator.

Adhesive with maximum inclinations of the ground dangerous due to the risk of overturning and sliding in travel

Note: The inclinations listed on the plate above refer to those LIMITS that cannot be exceeded with the machine. Almac s.r.l. has provided on the platform an electronic control system that limits translation of the machine upon exceeding of the maximum inclinations permitted.











The plates are affixed to the machine for the purpose of helping the operator and/or warning him of the risks to which he may be exposed when he uses the machine. In no way does the information on the plates substitute this Manual, which is the only reference document containing complete information.



Comply with the indications on the sign plates. Failure to comply with these indications may result in serious injuries and even death, and in any case could endanger the operators and/or exposed persons. Make sure that the sign plates are always affixed and legible. If this is not the case, they must be fastened back in place or replaced.

2.2.2 Meanings of the sign pictograms

	Warning / Danger. This symbol means that you must take care or that danger is present. Failure to comply with this alert indication could cause damage to the machine, the operator or exposed persons.
	Warning. This symbol means that you must take care of hot parts that could cause burns. Do not touch.
	Warning. This symbol means that you must take care of an electric panel or other live electrical devices.
	Danger. This symbol means that there is a danger of injury to the upper and lower limbs due to moving parts. Do not insert your hands or feet into openings that could move and cut or between moving parts.
	Forbidden. Means that it is forbidden to use water at high pressure on these surfaces
	Forbidden. Means that it is forbidden to climb onto the parts indicated by this symbol.
	Required. This symbol means that you must use the indicated anchor points for lifting the machine.
	Required. This symbol means that you must comply with the instructions in the “use and maintenance manual”.

2.3 Provisions and prohibitions

- Read this manual carefully before starting, using, servicing or performing other operations on the machine.
- The machine must always be kept in perfect conditions by following the maintenance program described in the *Maintenance Chapter*.
- Do not wear rings, wrist watches, jewellery, unfastened or loose clothing such as neck ties, torn garments, scarves, unbuttoned jackets or garments with open zip fasteners that could get caught up in moving parts.
- Wear approved safety garments, such as non-slip footwear and a reflective vest.
- Keep the control compartment and floors clean and free from any foreign objects or traces of oil, mud or snow.
- **USE OF THE MACHINE WITH OPERATOR ON THE LOADING PLATFORM IS FORBIDDEN.**
- **IT IS FORBIDDEN TO EXCEED THE MAXIMUM LOAD.**
- Do not use the controls or flexible hoses as hand grips
- Inform the maintenance managers of any irregularities in operation.
- Make sure that all guards and other protections are positioned correctly and that all the safety devices are installed and efficient.
- Do not use the machine in places where there is a risk of explosion or fire outbreaks.
- Do not use water jets or water cleaners to wash the machine.
- ***The operator is obliged***, according to the current-accident prevention regulations, to make use of a protective HELMET and safety shoes.
- The control stations must not be used if there is insufficient light as it is not fitted with its own lights.

2.4 Transport and loading

You are advised to check the dimensional limits established for means of transport if the machine must be transported to its specific work site.

The machine can be loaded onto the vehicle in two different ways:

- 1) **Using appropriate ramps and the machine translation commands:** In this case, make sure that the ramp gradient is within the gradeability indicated in the PERFORMANCE data and that the bearing capacity of the chutes suits the weight of the machine.

Note: The machine has an advanced traction control function "Direction-Control" (DC-S on the control panel) which allows it to be moved in a straight line using a single joystick. It is advisable to use this operating mode with the control stations in the maximum track width and in turtle mode, after aligning it with the ramps.

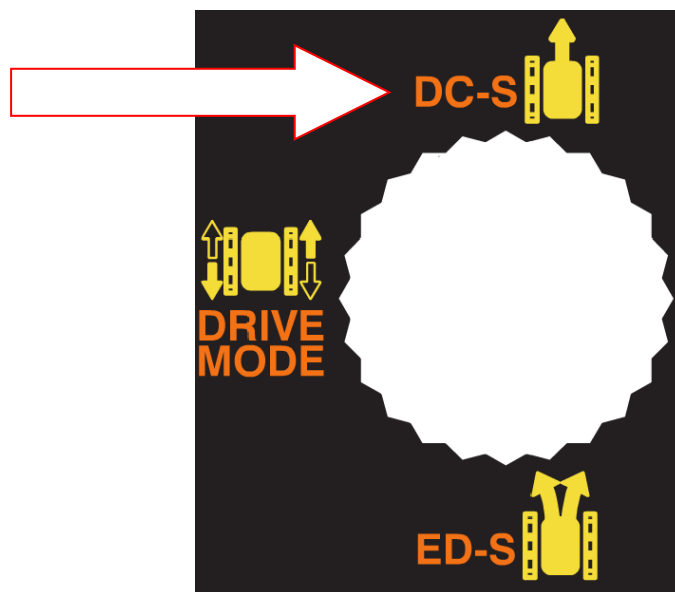

2) Lifting the machine by forklift using the relevant tubular elements.



Attention: the maximum weight of the machine in the heaviest configuration is 1800 Kg



Note: Once the machine is positioned on the vehicle, secure it by means of straps, connecting them to the appropriate holes on the frame.

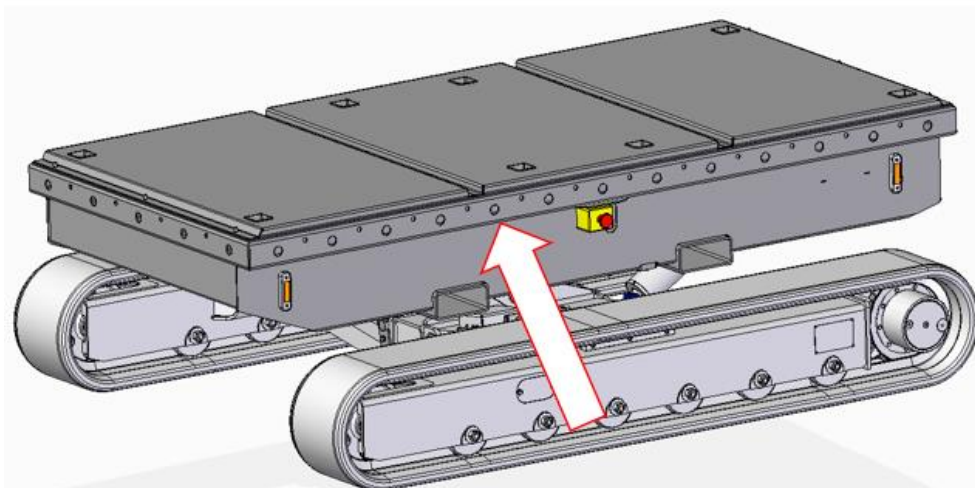

Warning: the chassis must be completely lowered (chassis wide)

Attention: Do not excessively tighten the fixing straps to avoid damaging the structure.

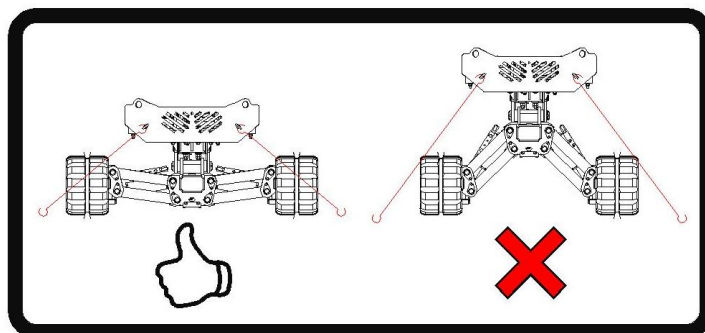

2.5 Checks on the machine before each use

- Make sure that there is no hydraulic oil leaking from the hoses and from the other components (cylinders, distributors, fittings, etc.).
- Check that there are no cut or worn electrical cables and that the connectors are correctly secured.
- Check the hydraulic oil level.
- Check that no screw, bolt or ring nut is loose or missing.
- Make sure that all the pins are in place and correctly secured.
- Check that the steel structure is not deformed.
- Make sure there are no cracks in the welds, damage or abnormal wear.
- Make sure the tracks are not cut or abnormally worn.
- Always check to make sure that track tension is correct.
- Check that the manual, the plates and the stickers are on the machine.

2.6 General safety instructions on use of the machine

The instructions given below must be followed.

- It is forbidden to work near high voltage overhead electric power lines. Moreover, the control stations must always be kept at a safety distance of at least 5 m from cables. For voltages greater than 132KV, refer to the table below.

Nominal voltage (kV)	Minimum distance (m)
≤ 1	3
$1 < U_n \leq 30$	3.5
$30 < U_n \leq 132$	5
> 132	7

- Do not use the machine during storms. You could be struck by lightning.
- Use the machine only in the temperature range permitted.
- It is forbidden to exceed the machine's capacity.
- It is forbidden to use the machine on soft, slippery or non-consistent soils.

Type of terrain, geomorphological characteristics	Permitted surface pressure	
Loose non-compact soil	In general, not solid; requirement for particular measures	
Mixed, compact soil, sand and gravel	2.0 kg/cm ²	0.2 N/mm ²
Semi-solid cohesive soil	1.0 Kg/cm ²	0.1 N/mm ²
Solid cohesive soil	2.0 Kg/cm ²	0.2 N/mm ²
Hard cohesive soil	4.0 Kg/cm ²	0.4 N/mm ²
Rock, concrete, road paving suited to the transit of heavy vehicles	Over 10.0 Kg/cm ²	over 1 N/mm ²

2.7 Safety indications on the use of the travel function

The instructions given below must be followed.

- Make sure movements are done on flat, sturdy ground.
- Make sure that there are no hollows or ridges in the floor and that there is enough room for the machine to pass through.
- Make sure that there are no bystanders or obstructions in the surrounding area before moving off
- Do not CHANGE DIRECTION on kerbs, rocks or appreciable differences in level (> 10 cm) when driving the machine. In this case, always proceed perpendicularly to the obstacles.

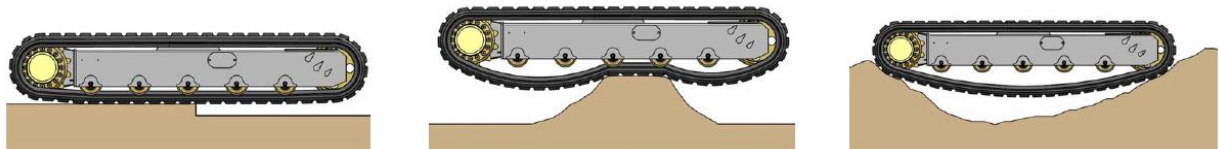

- If you must drive up a slope, do not change direction when the ground changes from flat to sloping. If this is absolutely necessary, perform the manoeuvre gradually.

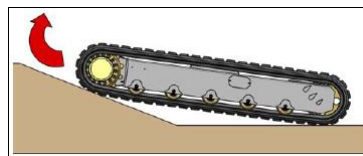

- Do not drive along the edge of slopes or over uneven ground with one track horizontal and the other slanting or partially raised (>10°) as this will

damage the tracks. ALWAYS PROCEED WITH THE TRACK SHOES RESTING ON THE SAME HORIZONTAL PLANE.

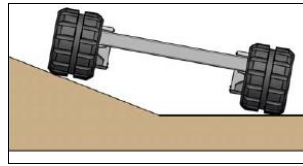

- Driving over an obstacle creates a gap between the bearing rollers and track, which could consequently slip out of its housing.

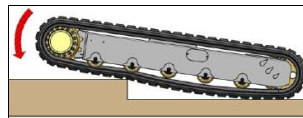

- If you change direction in a situation where the track could move sideways owing to an obstruction, the track could slip out of its housing.

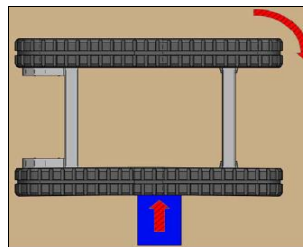

Attention: for inclined floors, pay attention to the correct LEVELLING direction. Avoid inclining the machine beyond the extent necessary towards the lower side of the platform!

- Avoid smooth, slippery and/or icy surfaces and those covered with sand: they could cause a risk of sliding or tipping during levelling.

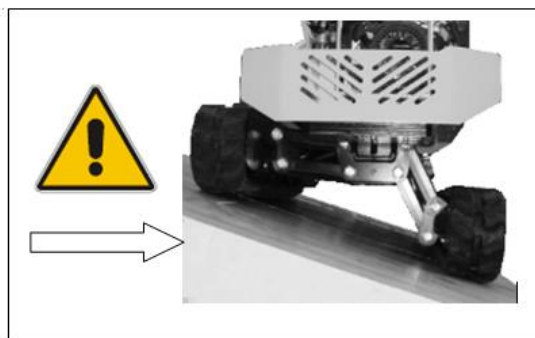

NO ICE!
NO SAND!
NO DUST OR SMOOTH SURFACES!



Attention: during movement with ELECTRICAL POWER, be careful of the connection cable in order to avoid dangerously crushing the cable itself!

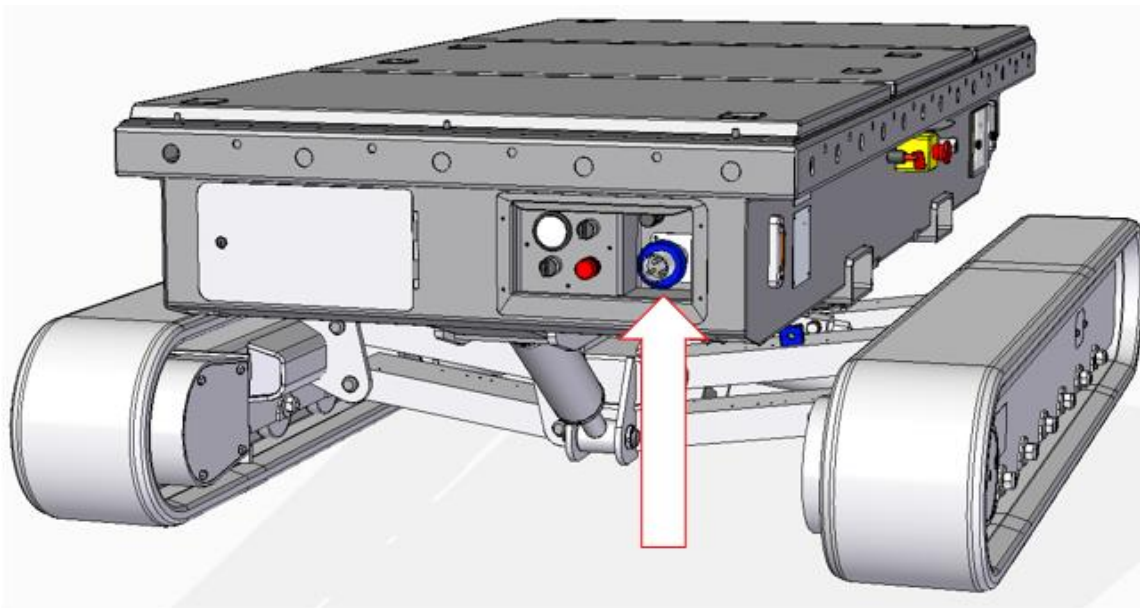

2.8 Safety checks on the operation of the machine, to be performed before use

The instructions given below must be followed.

- Position the machine with the frame inclined to the horizontal with a value greater than 0.5° on the side. Activate the automatic levelling control (Automatic levelling), make sure that the system automatically keeps the frame horizontal.
- Position the machine with the frame inclined to the horizontal by a value greater than 0.5° on the longitudinal. Activate the automatic levelling control (Automatic levelling), make sure that the system automatically keeps the frame horizontal.
- Position the machine with the frame inclined to the horizontal at the maximum angle both on the longitudinal and on the side. Activate the automatic levelling control (Automatic levelling), make sure that the system automatically keeps the frame horizontal.
- Lift the loading platform (without load) to the maximum height and then lower it a few times; make sure that the machine works correctly.
- Operate the emergency button on the remote control; make sure that the machine is switched off and that no function is permitted. Release the mushroom-shaped button after this test.
- Operate the emergency buttons on the ground (it is necessary to test the 3 buttons present); make sure that the machine is switched off and that no function is permitted. Release the mushroom-shaped button after this test.
- Operate the warning buzzer and make sure it works.
- Check the operation of the buzzer when the drive function is activated.
- Check with the machine in translation (with translation selector in DM) that releasing the Joysticks the machine stops immediately.

2.9 Precautions when work terminates or is interrupted

It is forbidden to leave the machine unattended without having first stopped the engine and removed the keys from the control panel to prevent the machine from being used by unauthorised persons.

2.10 Safety regulations during maintenance



The maintenance operations described in this Manual refer to machines in conditions of normal use. In heavy duty use conditions (e.g. extreme temperatures, dust and corrosive substances in the environment, etc.), inform the ALMAC S.r.l. assistance services to have the maintenance intervals checked and changed.

The MAINTENANCE operations must only be performed by authorised and adequately trained personnel.

Only perform the MAINTENANCE and ADJUSTMENT operations described in this Manual. Contact the ALMAC S.r.l. assistance service only, if other operations are required (e.g. if faults occur).

All MAINTENANCE work must be performed in compliance with the laws in force governing safety and protection of the environment.

THE MANUFACTURER IS RELIEVED FROM ALL LIABILITY FOR ACCIDENTS OR FAULTS DUE TO FAILURE TO COMPLY WITH THE RECOMMENDATIONS AND SAFETY REGULATIONS.

- Proceed with maintenance operations only after turning off the machine and deactivating the battery disconnect switch.
- Before proceeding with the interventions, make sure the machine is completely blocked.
- Protect the environment: avoid spilling oil when changing it or topping up. Used oil must be disposed of in accordance with the laws in force.
- Never insert the body, limbs or fingers in sharp, jointed opening on the machine that is not controlled or without proper guards unless securely blocked.
- Never use petrol, solvents or other flammable liquids as detergents. Always use authorised non-flammable and non-toxic commercial products.
- Do not use open flames for lighting purposes when performing maintenance.



- Make sure there are no fluids under pressure before disassembling unions or pipes: oil spattering out under pressure can cause serious injuries. Immediately call a physician if injuries occur or the fluid from pipes is accidentally ingested. Remember that fluid seeping from a very tiny hole can be almost invisible but possess sufficient force to penetrate under the skin. Use a piece of card or wood to check for leaks.
- Make sure that all parts of the hydraulic circuit have been tightened correctly
- When compressed air is used for cleaning parts, protect yourself by wearing safety goggles with side guards and limit the pressure to 2 atm maximum. (1.9 bar).







2.11 Personal protective equipment (PPE)

To operate the machine in complete safety, it is necessary to use appropriate personal protective equipment, which must be worn before climbing onto the work platform and used as indicated.

- Safety helmet
- Safety shoes
- Protection Gloves
- Goggles/Visor

PERSONAL PROTECTIVE EQUIPMENT

			
Body protection is compulsory	Safety gloves are compulsory	Safety footwear is compulsory	Ear muffs or earplug are compulsory

2.12 Precautions and indications of the battery pack

General information

The machine is equipped with a series of 8 6V batteries, whose technology is comparable to the AGM (NO GAS) one. The resulting nominal voltage of the battery series is 48V.

The design, weight and dimensions were devised considering safety aspects, especially spaces and insulations.

The use of batteries not approved by Almac S.r.l may detract from the performance and reliability of the machine.

In the event of significant differences, problems of electrical insulation of the machine can be highlighted with all the associated risks.

Low ambient temperature reduces battery capacity, high temperature reduces lifespan.

Batteries series technical specifications	
Nominal Capacity [Ah]	180Ah
Nominal voltage [V]	48V (6 x 8)
Number of batteries (Battery series)	8
Maximum End Charge Voltage [V]	55V
Minimum Operational Voltage [V]	45V
Nominal Discharge Current [A]	100 A
Maximum Discharge Current [A]	120 A
Nominal Charge Current [A]	40 A
DOD (Depth of discharge) [%]	80%
Useful Life	≥2000Cycles@80%DOD
Operational Temperatures	-30°C / +55°C *
Operational Temperatures (Discharge)	-30°C / +55°C
Battery Dimensions (L*W*H) [mm]	260 * 180 * 270
Batteries Series Weight [Kg]	264 (33 x 8)
Technology	Lead Crystal Acid

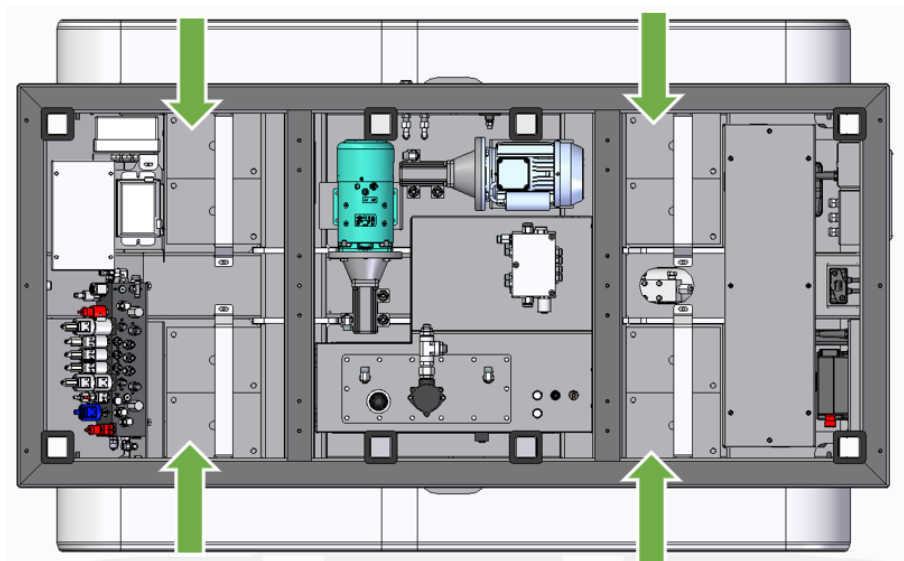

2.13 Batteries Maintenance and Verification

2.13.1 Clothing

Always wear a visor or goggles when operating on the batteries.

Wear plastic gloves, an apron or overall to protect your clothes; remove bracelets, rings or other metal objects that could cause short involuntary circuits.

2.13.2 Batteries status verification

- a. The batteries must be dry and clean;
- b. The terminals for connection to the poles must be clean and adequately protected by the protective caps.

2.13.3 Replacement of individual batteries

- a. Disconnect the power supply of the machine via the battery switch;
- b. Remove the two planes A and B

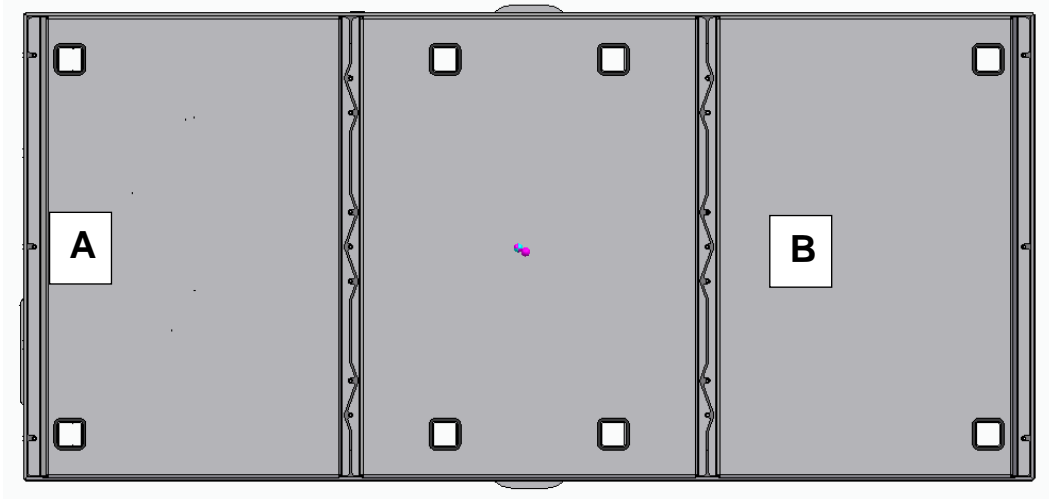

- c. Disconnect the GND battery negative pole (see photo below) taking care to keep the disconnected part well insulated, protecting it adequately. By way of example only, achieve this with insulating tape or with plastic casing.

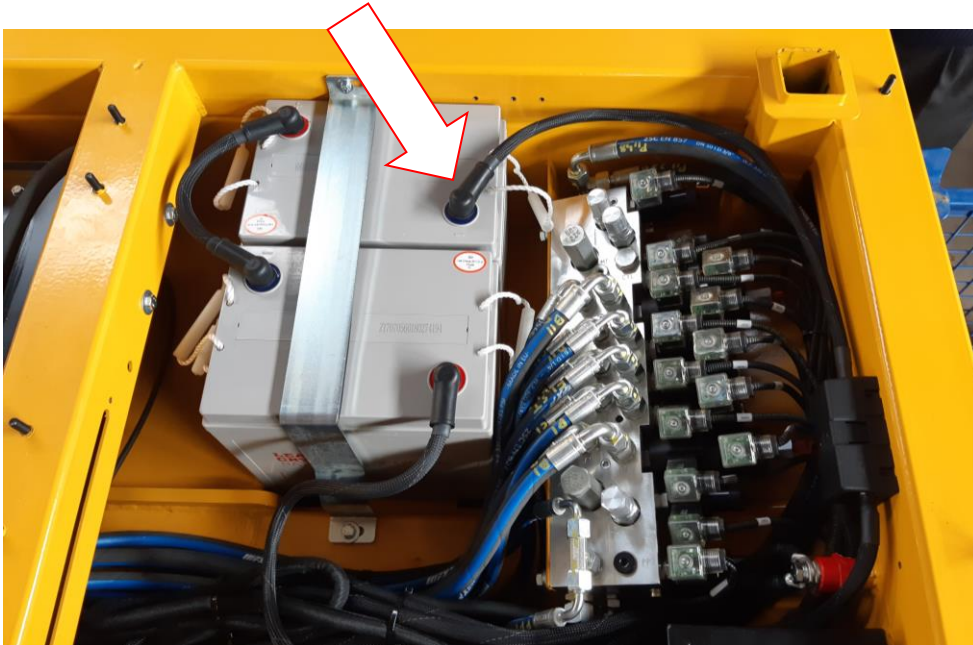

- d. Disconnect the +48V battery positive pole (see photo below) taking care to keep the disconnected part well insulated, protecting it adequately. By way of example only, achieve this with insulating tape or with plastic casing.

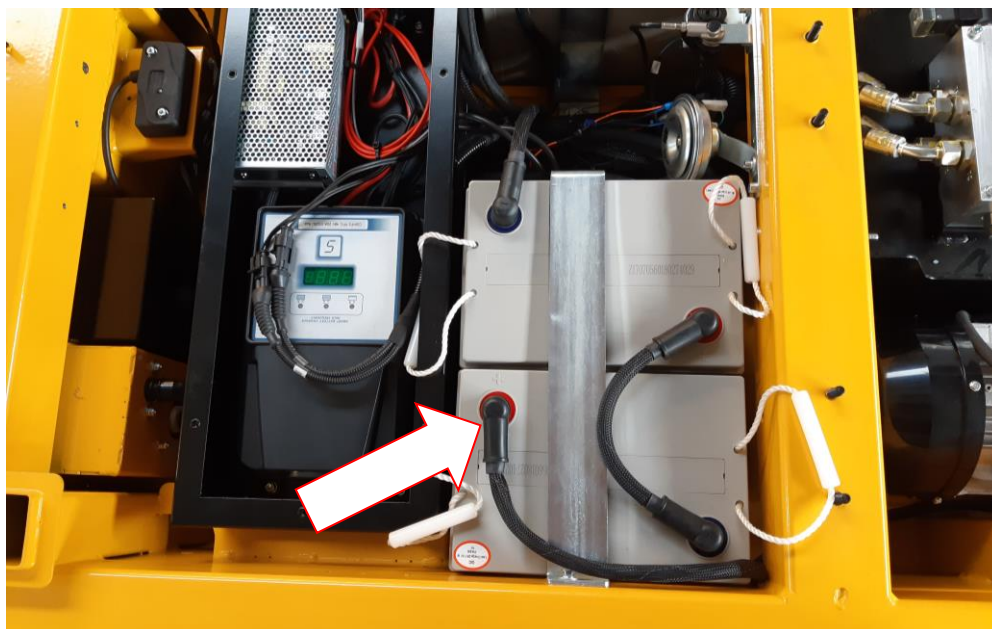

- e. Once all the operations have been performed up to point d, each individual battery (6V) can be replaced by removing the mechanical fixing (See photo indication).



This can also be achieved by disconnecting the poles (as shown in the figure below) having also in this case protected and isolated them.

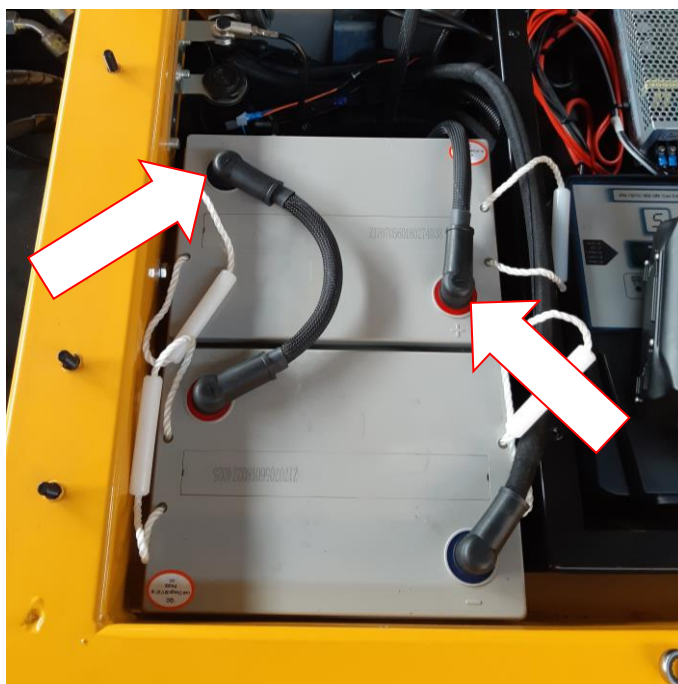

2.14 Battery status maintenance

The machine stored without recharging of the batteries can remain for up to 3 months at a temperature of 20° or 2 months at 30° .



Attention: Always wear a visor or goggles when operating on the battery.

Wear plastic gloves, an apron or overall to protect your clothes.

remove bracelets, rings or other metal objects that could cause short involuntary circuits.

Carefully read the instructions for use and maintenance before carrying out any operation with the battery.

Contact the manufacturer in case of difficulties or uncertainty.

Place the batteries and electrical appliances out of the reach of children.



Attention: Do not expose the battery to heat, fire or microwave.

Do not expose to temperatures higher than 60°C: danger of explosion.

Do not deposit the battery together with other metal objects (such as the toolbox) or with other batteries. Danger of generating an electric short circuit.

3 DESCRIPTION OF THE MACHINE

3.1 Structure of the equipment

This section describes the main components of the machine and their functions.

1. Control push-button panel (console)



2. Control console emergency button



3. Remote control compartment



4. Remote control charge



5. Main differential panel



6. Ground control panel



7. Main hydraulic unit



8. Flashing light



9. Ground control panel emergency button



10. Electronic control unit (ECU)



11. Remote control unit



12. Remote control battery recharge compartment



13. Remote control emergency cable connector



14. Battery disconnect switch



15. Emergency button right side



16. Emergency button left side



17. Hydraulic oil tank

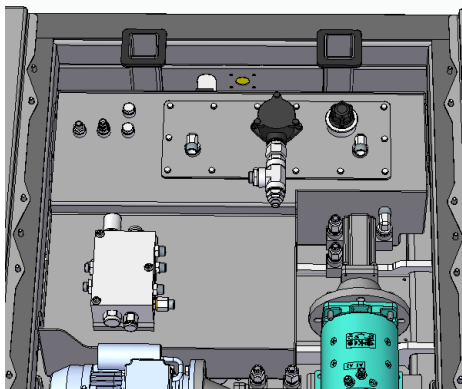

18. Discharge filter



19. Intake filters (in the tank)

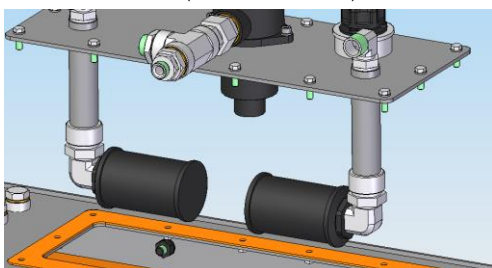

20. Oil tank refill cap

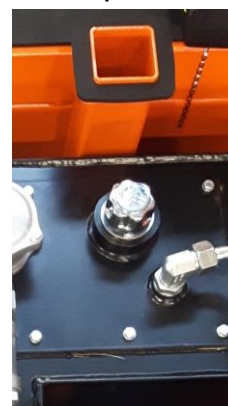

21. Visual hydraulic oil level



22. Booster for translation speed management

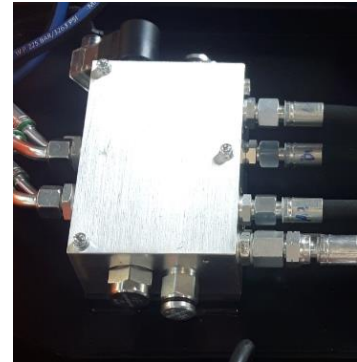

23. Electric motor AC 110V or 220V

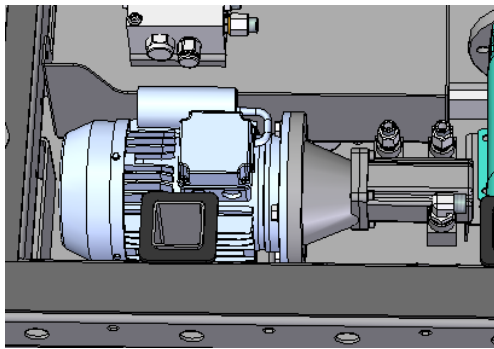

24. Electric motor DC 48V

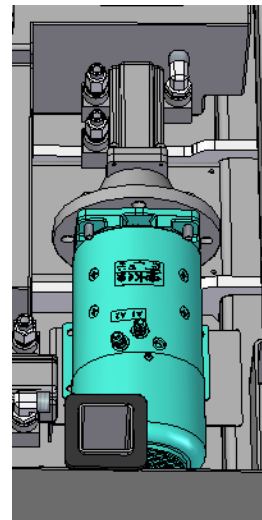

25. Batteries



26. Battery charger

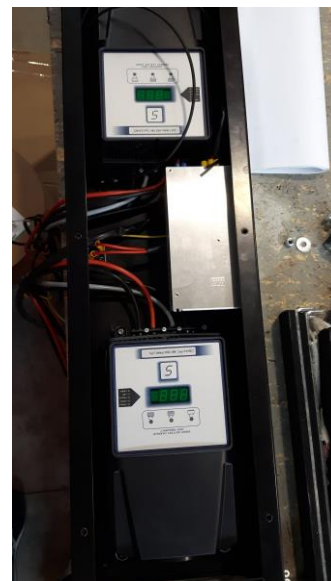

27. Contactors group



28. Converter 220V/110V - 12V



29. Frame angle sensor



30. Rod angle sensor

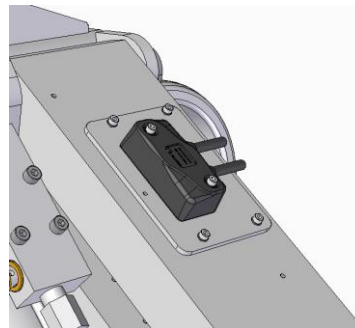

31. Chassis angle sensor

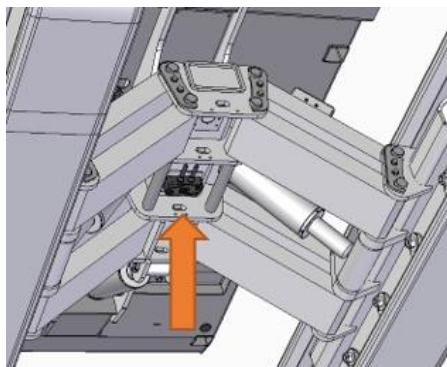

32. Bi-levelling chassis

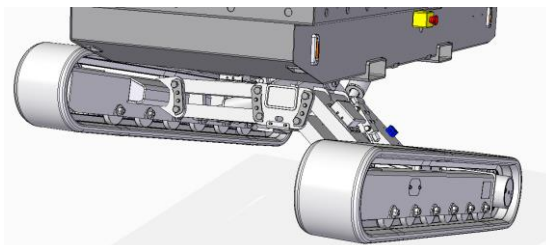

33. Attacchi rapidi



3.2 Control stations

3.2.1 Mobile control push-button panel (console)

The machine is equipped with a mobile control push-button panel (console) that allows normal operation with the operator on the ground.

In the event of an emergency, the push-button panel can also be connected to the supplied cable by tightening the appropriate ring indicated.



The push-button panel, when use of the machine is completed, must be stored in a compartment closed by a door fitted with a key lock

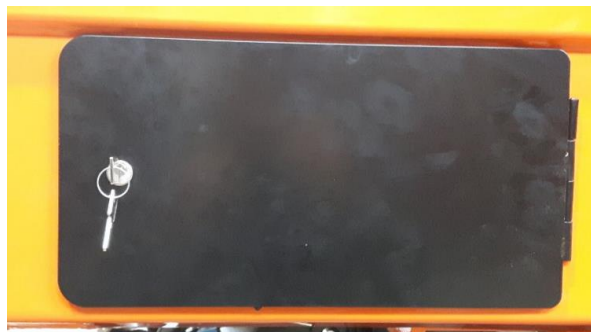

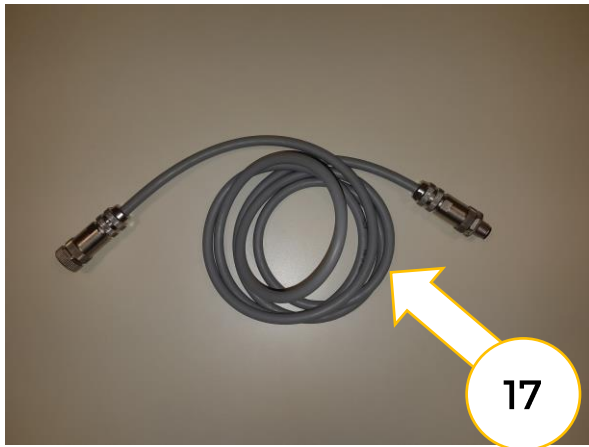
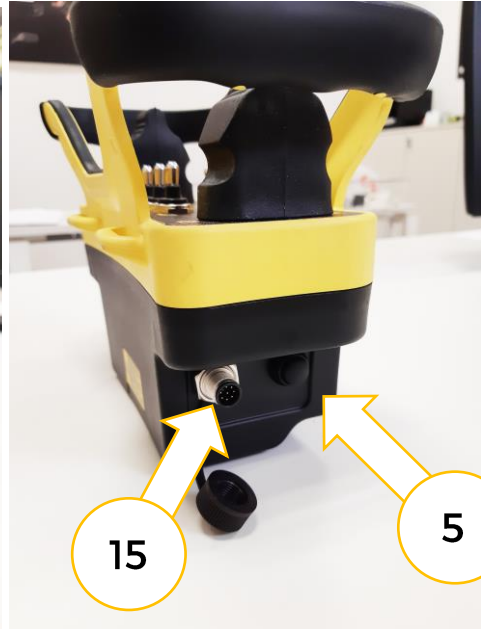
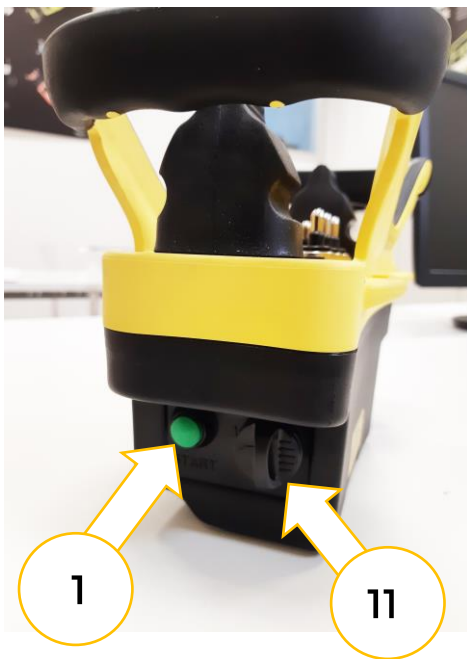
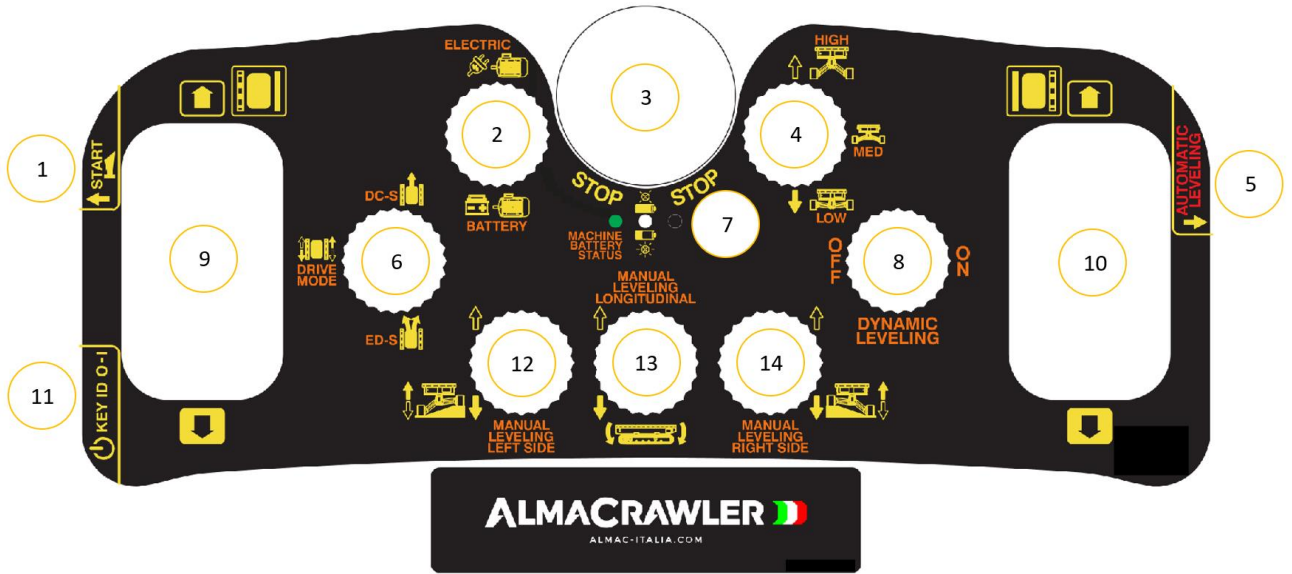

No.	Identification	Function and Status	Description of the function
1	Button (START)	<p>ENGINE IGNITION AND AUTOMATIC LEVELLING</p> <p>Ignition of machine and console</p>	<p>1. Press the button to access the radio control (after releasing the emergency mushroom);</p> <p>2. Press the button again to activate reception (Radio console with machine); in this way the platform electrical system is activated;</p> <p>3. Press the button to activate the console controls;</p> <p>4. When the machine is on it also acts as an acoustic signalling device.</p>
2	Selector	<p>ELECTRIC MOTOR SELECTION</p> <p>ELECTRICAL ENGINE position</p> <p>BATTERY ENGINE position</p>	<p>Powering of electric motor AC 110V or 220V.</p> <p>To switch on the electric motor, press the button (1) located on the left side of the console.</p> <p>The electric motor only works if the plug on the back of the machine has been connected to an external power source.</p> <p>Powering of electric motor DC 48V.</p> <p>To switch on the electric motor, press the button (1) located on the left side of the console.</p>
3	Emergency Button	EMERGENCY STOP	
4	Selector	<p>MACHINE DYNAMICS POSITION SWITCH</p> <p>HIGH position</p> <p>MED position</p> <p>LOW position</p>	<p>The loading platform remains always positioned at the maximum height permitted. This allows the passing through openings with a minimum width of 1.47 meters.</p> <p>The loading platform remains always positioned at an intermediate height.</p> <p>The loading platform is always positioned at the minimum height permitted. This allows the passing through openings with a minimum</p>

No.	Identification	Function and Status	Description of the function
			height of 0.75 meters.
5	Button (AUTOMATIC LEVELLING)	Automatic levelling	Automatic levelling of the machine on all the axes.
		DRIVING MODE SELECTOR	
6	Selector	Position DRIVE MODE	Standard operation - traction FORWARD/REVERSE enabled using 2 joysticks.
		DC-S position	Simultaneous movement FORWARD/REVERSE of the tracks with the RH joystick only (10).
		ED-S position	Easy Drive System assisted drive control system.
7	LED light (green and red)	Lights relating to the operating status and battery of the radio control	Refer to the radio control manual.
		DYNAMIC LEVEL SELECTION	
8	Selector	DYNAMIC LEVELLING ON position	Dynamic levelling activation during translation.
		DYNAMIC LEVELLING OFF position	Non-active dynamic levelling during translation.
9	LH joystick		Left track FORWARD/REVERSE travel control.
10	RH joystick		Right track FORWARD/REVERSE travel control.
11	Safety key (KEY)	Safety key for console activation	Insert the supplied key to activate the console; If the key is not inserted, the console cannot be activated; The key is encrypted so use only the key provided, otherwise the console cannot be used.
12	Selector		Left rod manual levelling.
13	Selector		Longitudinal manual levelling.
14	Selector		Right rod manual levelling.

No.	Identification	Function and Status	Description of the function
15	Connector	Auxiliary connector for places where radio frequencies cannot be used.	
16	Battery	Battery necessary for console power supply.	
17	Cable	The cable is used in this particular condition: - Use of radio remote control via cable (radio bridge by-pass).	

3.2.2 Ground control using the mobile push-button panel

The machine has been designed and built to be driven by an operator on the ground.

The push-button panel works in radio control mode but in case of emergency it is possible to connect the console using the cable supplied.



When operating, be careful not to come into contact with the platform tracks. Stay at a safe distance.

3.2.3 Ground controls

The platform features a control console located on the chassis at the back of the machine. These commands are for the operator in case of emergency situations (red mushroom button).

Attention: The key must always be available.

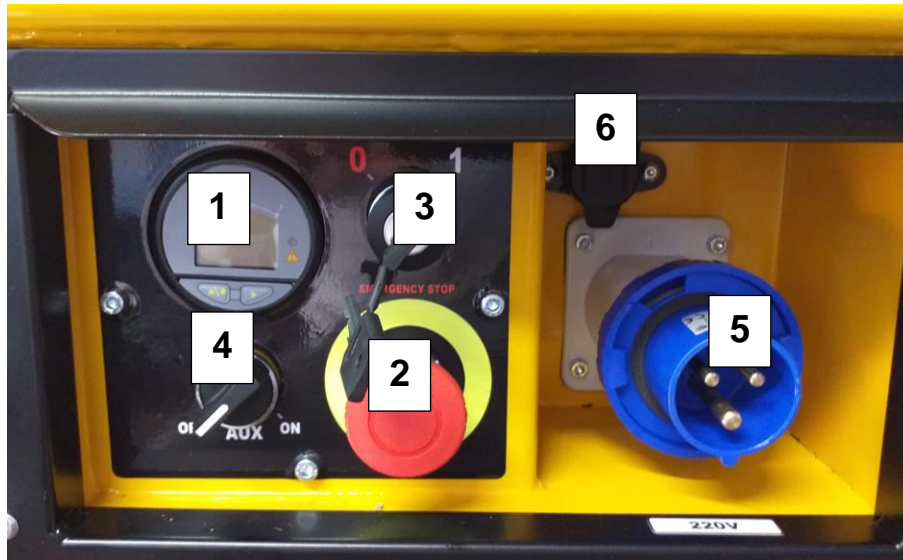

	Identification	Function and Status	Description of the function
1	Display	Display of the hours of operation and machine status, with an indication of any alarms.	
2	Emergency Button	EMERGENCY STOP	
3	Key selector	MACHINE ON / OFF	
		Left position (0)	Machine turned off.
		Right position (1)	Machine turned on.
4	Key selector	RAPID COUPLINGS SELECTOR (OPTIONAL)	
		Left position (OFF)	The rapid hydraulic connections (on the right side of the machine) are disabled and the machine works normally.
		Right position (ON)	Pressure is applied to the rapid hydraulic connections (on the right side of the machine), all the machine functions are disabled.
5	Connection plug	Plug for the connection of electricity to the network. Required for handling the AC motor (110V or 220V) and for recharging of the traction batteries.	
6	3-pole outlet	12V auxiliary outlet (Connection for powering of winch kit if present)	



Attention: the 20A recharge is only necessary if a current is available from the panel of max 10Aac, but, mainly, use the 40A recharge to maintain the optimal state of the batteries.

3.3 *Operating safety devices*



Attention: Periodically verify that the safety devices are operating correctly. During work, the operator must be able to assess, recognise and avoid all dangers and must immediately inform the persons in charge of any faults in the safety devices so that they can be inspected and restored to their original conditions of safety and reliability.

DO NOT TAMPER WITH AND DO NOT CHANGE THE CALIBRATION OF ANY OF THE COMPONENTS OF THE ELECTRICAL AND HYDRAULIC SYSTEM.

The machine includes a complete set of safety devices.

3.3.1 **Main frame inclination control device**

On the machine Frame there is a Can Bus angle sensor that constantly communicates the inclination measured to the electronic control unit.

The angle sensor is redundant (thus consisting of two separate sensors) and the X and Y inclination axes of the machine are monitored (lateral and longitudinal). The signals of the two sensors are constantly compared with each other to assess their consistency.



3.3.2 Chassis tilt control device

A Can Bus angle sensor is fixed to the machine's chassis which constantly transmits the measured inclination to the electronic control unit.

The angle sensor is redundant (thus composed of two distinct sensors) and the Y axis of machine inclination (longitudinal) is monitored.

The signals of the two sensors are constantly compared with each other to assess their consistency.

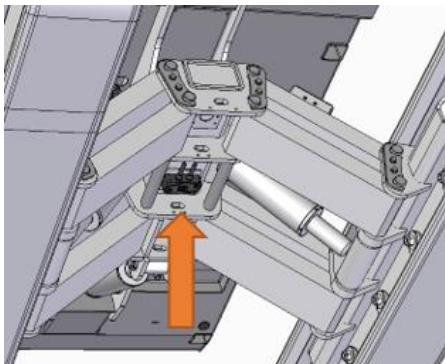

3.4 Hydraulic system safety devices

3.4.1 Hydraulic pressure limiting devices

The hydraulic system of the machine has appropriate general maximum pressure valves (1-2) in order to limit the pressures relative to the operation of the machine, preserving the integrity of the various components.

These valves do not require adjustments as they are calibrated directly by ALMAC S.r.l. At the testing phase. The diagram below illustrates the integrated power pack and the position of the pressure relief valves described above.

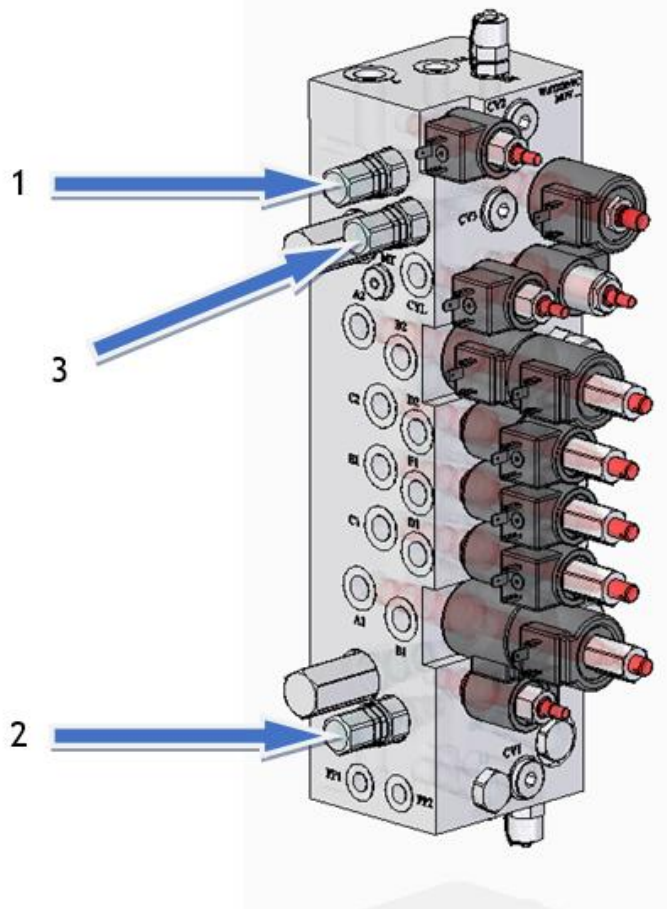

1. Maximum system pressure valve : set to 220 bar;
2. Maximum system pressure valve : set to 220 bar.



Warning: modifications to the positions of the maximum pressure valves without authorization from ALMAC S.r.l. will void the warranty and any claims made by the customer.

3.4.2 Hydraulic block safety devices

The hydraulic block features three solenoid valves with possible manual by-pass. These solenoid valves, indicated with 1-2-3, are part of the safety system of the machine and **must never be operated manually.**

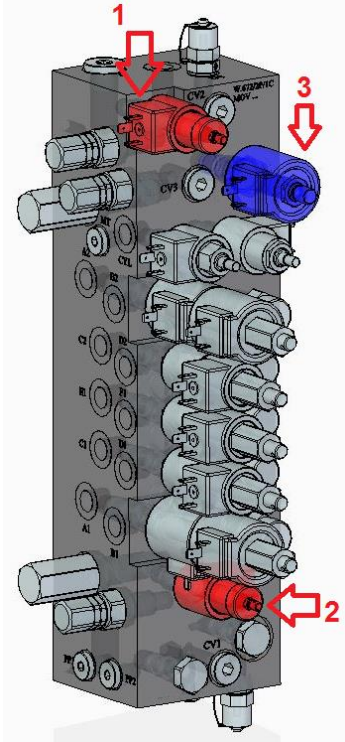

ATTENTION: If the valve 3 is not fully inserted by pressing and turning clockwise (hearing a click) and the valves 1-2 are all unscrewed and locked with a seal, the safety of the machine will be compromised.

If there is an accidental failure of one of the hydraulic pipes that feed the levelling cylinders of the tracked chassis, with consequent sudden variation of the roadway and the inclination, appropriate **BALANCING VALVES** prevent sudden movement of the chassis.

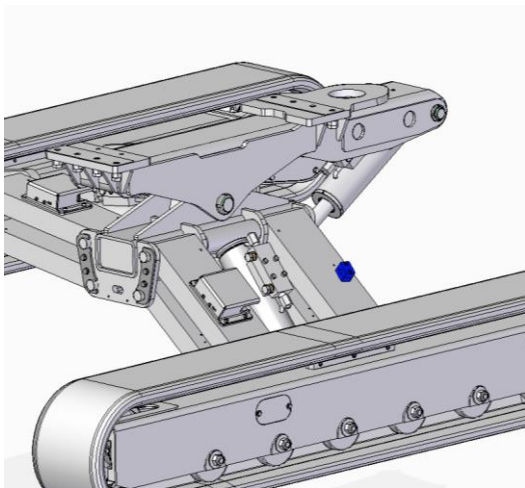
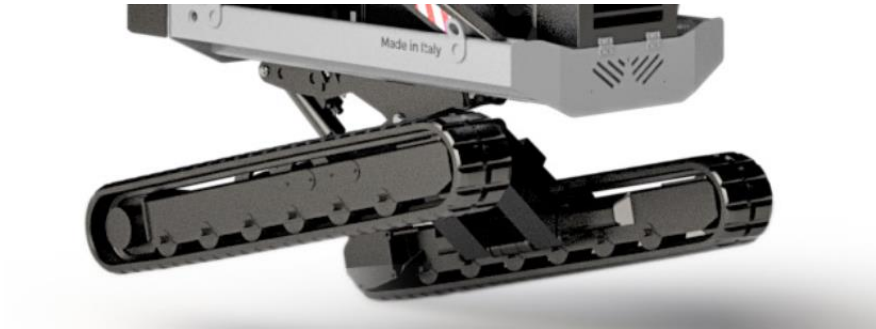

LEVELLING – RIGHT SIDE

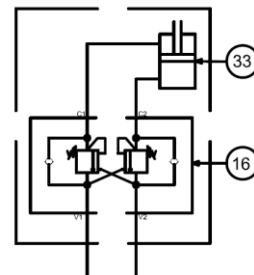

Proceed as described below to restore the machine to normal operating conditions:

1. Repair the damaged hydraulic hose and/or connections;
2. Fill and bleed the hydraulic circuit;
3. Manually perform the lateral and longitudinal levelling.

3.5 Blackout safety devices

3.5.1 External power source 230V or 110V

On the machine there is a plug to power the AC electric motor or the battery chargers to recharge the traction batteries. For safety reasons, a device is installed so as to cut-out the electricity supply in case of over-voltage and "differential circuit breaker" dispersions (1).

To access the device, it is necessary to unscrew the dedicated knobs on the cover itself, removing the transparent protection panel (2) and open the electrical box cover. When finished, replace the guard that was previously removed and thoroughly tighten the knobs.



3.5.2 12V-48V system

On the right side of the machine is the "battery disconnecter" (3) that physically disconnects the 48V power line coming from the battery and supplies the various users, and the 12V line of electronic power supply and utilities.

It is recommended to operate this device at the end of the work day, to prevent draining the batteries.

Inside the frame there are also safety fuses to protect the 12V electric devices.

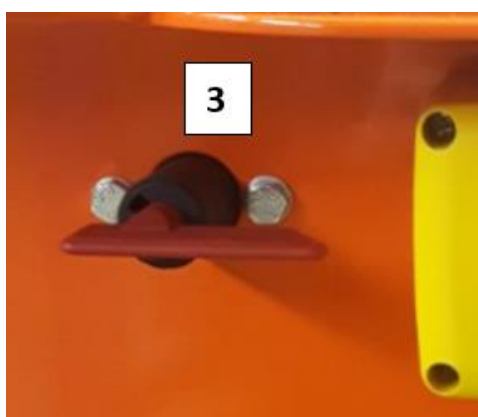

Power fuses



Safety fuses



3.6 Platform operation devices which are not part of the safety system

On both connecting rod assemblies (right and left) connecting the tracked chassis and the central frame, there are two Can Bus angle sensors.

The angle sensors are redundant (thus consisting of two separate sensors) and monitor the X inclination axis of the respective connecting rod.

The values of the two sensors are constantly compared with the X values of the sensors attached to the frame.

By measuring their difference, it is possible to determine the relative position of the connecting rod with respect to the frame.

The position of the two connecting rods is used by the control unit to decide which one should be moved during the lateral levelling operations (according to the X axis).

Since neither the travel height nor the operating height depend on the position of the connecting rods, they are not part of the safety system but only of the system required for the operation of the machine.

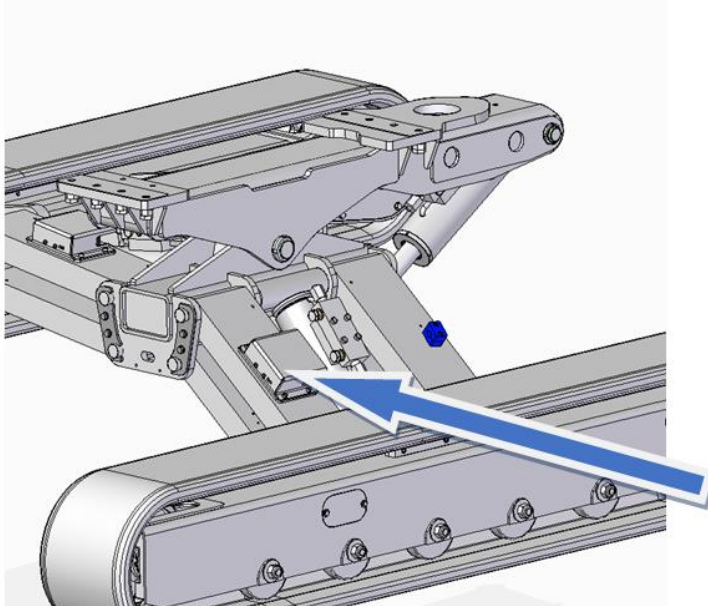

4 Instructions for use

4.1 Preliminary operations

4.1.1 Suitability of the soil

To assess whether the ground is fit to bear the machine, it is extremely important to ensure that the ground surface does not allow the machine to slip once it has been stopped for work.

Two factors contribute towards increasing the danger of slipping:

- Slope;
- Poor grip (or slipperiness) due to a low friction coefficient.

These two factors must be assessed with the utmost care, and at the same time as each other. There are no acceptable values for one "factor" that can exclude the risk of slipping if the other factor is extremely unfavourable. Ground that is almost flat may not be fit if its surface is icy. On the other hand, a surface with high adhesion may not be fit if it slopes too steeply.

The ideal condition for stability of the machine is represented by flat and horizontal terrain even if in fact this ground condition occurs very rarely.

- Avoid smooth, slippery and/or icy surfaces and those covered with sand: they could cause a risk of sliding or tipping during levelling.

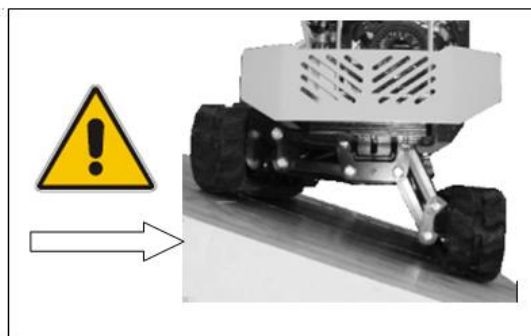

Note: Do not use the machine if you are uncertain about the fitness of the ground surface.

- NO ICE!
- NO SAND!
- NO DUST OR SMOOTH SURFACES!

4.2 Machine operation

4.2.1 Powering of the machine.

To turn the machine on, it is necessary to reset all the emergency mushroom buttons (side, ground panel and console) and to turn the key selector located in the ground controls to position 1;



The key-switch functions are:

- (RIGHT POSITION - 1): machine on - energised electrical system.
- (LEFT POSITION SX - 0): machine off - de-energised electrical system.

To turn on the machine proceed as follows:

- Press button (1) to access the radio remote control;
- Press the button (1) again to activate reception (Radio console with machine); in this way the platform electrical system is activated;
- Press the button (1) to activate the controls in the console;

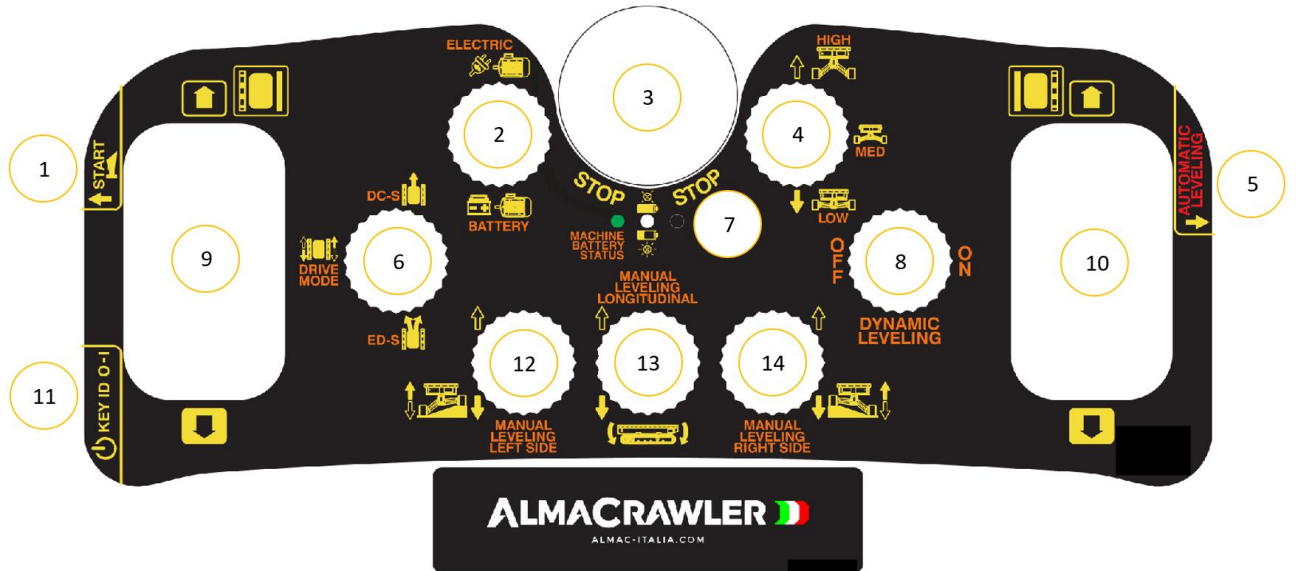

ATTENTION!

If the RED led (7) lights up when the machine is switched on, it means that an active command is already present at start-up (Joystick contact or movement selector jammed).

Once ignition is completed it is therefore possible to start the motor:

- Operate selector no. 2 for motor selection
 - High position: AC 110V or AC 220V electric motor (attention: to use this motor it is necessary to connect the mains power plug);
 - Low position: 48V DC electric motor.

4.2.2 Travel controls

The controls used for the movement of the platform are represented by 2 joysticks (9-10) located on the control panel. (see photo below).

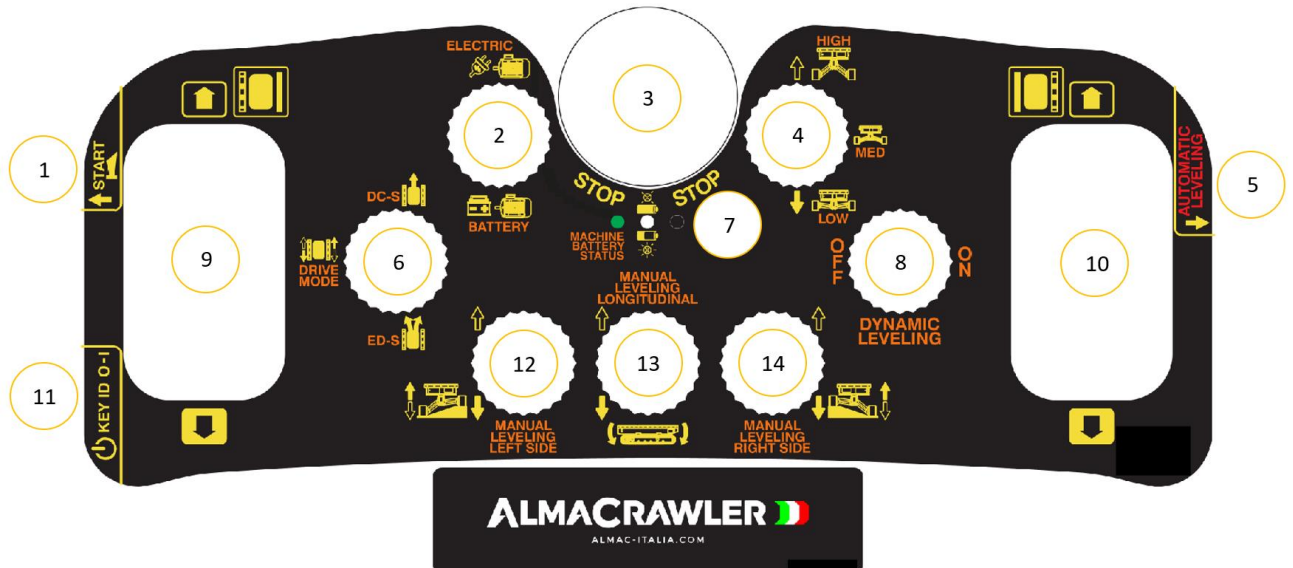

Each lever controls the respective track (right lever→right track, left lever→left track).



Move the lever forwards to drive the platform forwards. Move the lever backwards to drive in reverse.

You can work with one track at a time, depending on the movement required at that particular moment.

The platform is fitted with a tracked chassis with dual speed gear motors equipped with a negative brake, therefore the machine will remain blocked whenever the forward or backward movement is interrupted.

To turn the control stations, move the levers as indicated in the following illustrations.



	Left turn
	Rotation on itself towards the right (counter-rotation)
	Rotation on itself towards the left (counter-rotation)

ATTENTION: If you must drive up a slope, do not change direction when the ground changes from flat to sloping. If this is absolutely necessary, perform the manoeuvre gradually.



It is forbidden to climb on the tracks to try to perform any operation that is not permitted.

It is forbidden to climb on the tracks when the machine is moving.



4.2.2.1 *Standard travel mode*

With the selector (6) on the central position "DRIVE MODALITY", it is possible to carry out all the translation movements with independent tracks (see paragraph 4.2.1).



4.2.2.2 Easy-Drive System (ED-S)

Moving the selector (6) on the push-button panel to the "ED-S" position activates a special function that allows you to control the rotation of the control stations, especially when operating on cultivated or grassy terrain, so that the tracks do not rip the cultivation during the manoeuvre.



In fact, the activated function controls, in addition to the selected track, also the movement of the other track but at a lower speed.

This allows for controlled steering.

When this function is selected, counter-rotation is not enabled.

4.2.2.3 Direct-Control System (DC-S)

By moving the selector on the push-button panel to the "DC-S" position, you can use only the right Joystick (10) to move in the driving direction, maintaining a straight trajectory without having to correct the direction with the other joystick.

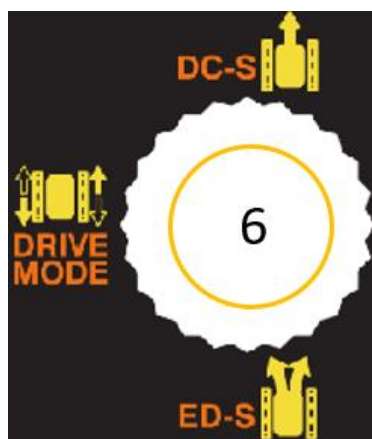

4.2.2.3.1 Dynamic Levelling ON

During translation the levelling is automatically performed to ensure the loading platform is always parallel to the ground in any translation mode.

4.2.2.3.2 Dynamic Levelling OFF

During translation the loading platform remains fixed and is not self-levelling. If the DC-S mode is selected, they are automatically inserted:

- Booster: the hydraulic motors are connected in series with consequent doubling of the speed.
- the displacement change of hydraulic motors: they are activated in small displacement allowing a further increase in speed (reducing the traction capacity)

To use this function in the best way, it is advisable to control both Joysticks in the desired direction first and then move selector 6 from DM to DC-S.

At this point it is possible to release the left joystick and to keep holding only the right one. The machine will continue to move straight at maximum speed.

Attention: It is not possible to perform the reverse procedure; once the machine travels in DC-S it cannot go back to DM, not even if selector 6 is moved.

It is only possible to stop the machine completely by releasing the right joystick.

Attention: When the joystick is released, the machine will not stop immediately but there is a deceleration ramp. The space travelled before it stops can even be of 50 cm.

4.2.3 Machine levelling

The machine is equipped with an automatic levelling system with hydraulic cylinders, to allow the machine to operate within the maximum inclination permitted, thus always keeping the loading platform horizontal with respect to the ground within a range of $\pm 0.5^\circ$, both longitudinally (longitudinal cylinder) and laterally (connecting rod cylinders).

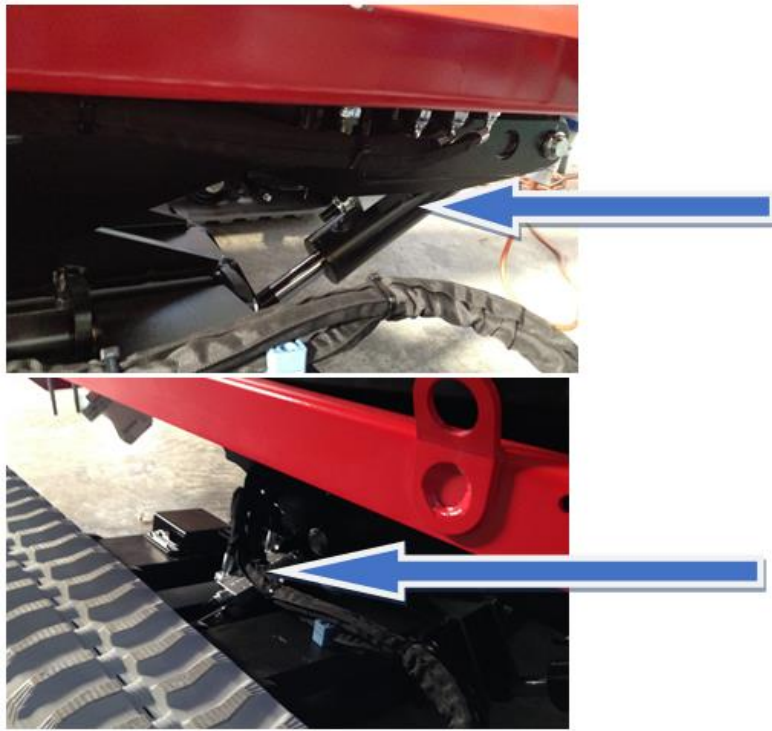

The maximum level configurations envisaged for the tracked chassis are shown below.

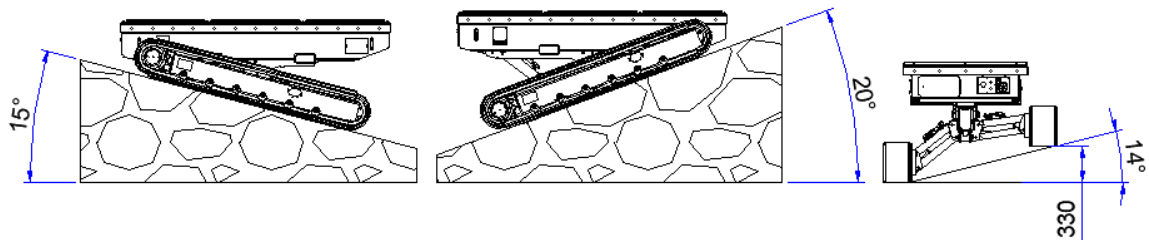

4.2.3.1 Automatic levelling

It is possible to activate automatic levelling by pressing the black button (5) located on the right side of the console.

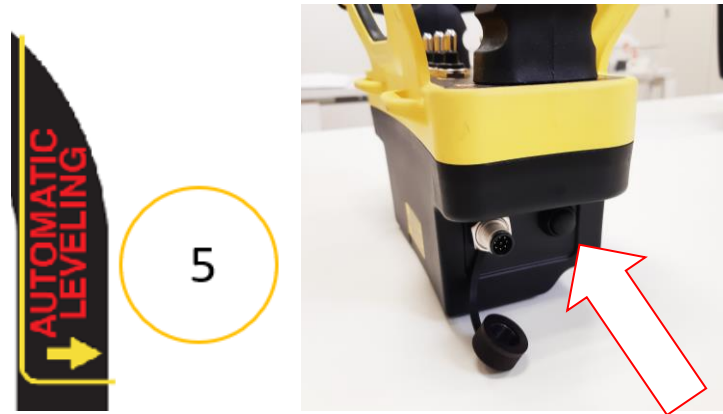

The system will bring the frame back to an inclination of less than 0.5° compared to the horizontal.

4.2.3.2 Manual levelling

LH lateral levelling

RH lateral levelling

Longitudinal levelling



By activating any movement, the platform will stop automatically once it reaches the horizontal.

Warning: manual levelling is less accurate than automatic levelling.

4.2.3.3 Dynamic Levelling during travel

Thanks to this system the machine, during translation, remains constantly levelled.

To activate this mode, it is necessary to turn the selector 8 of the push-button panel to the "DYNAMIC LEVELING ON" position and the selector 6 to the "DRIVE MODALITY" or ED-S position.

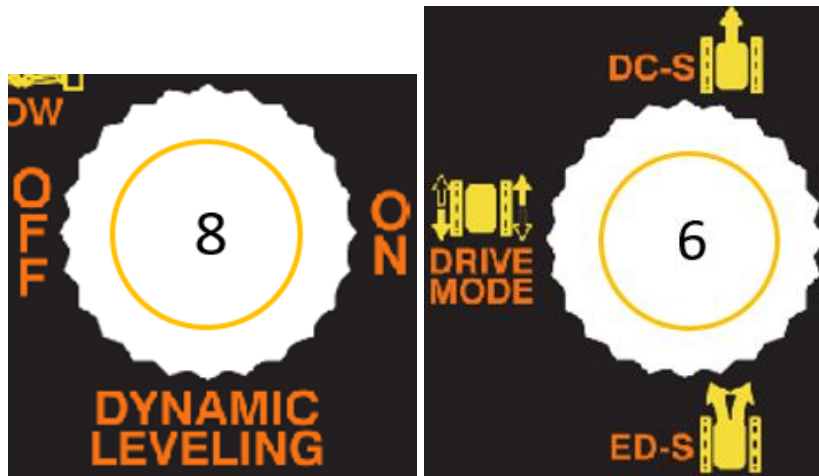

Attention: If the selector 6 is positioned in DC-S the function is active, but the Booster valves and displacement exchange are not inserted.

4.2.3.4 Dynamic Position System

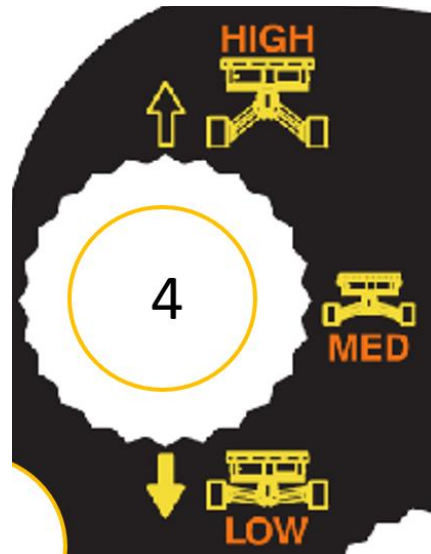

This selector allows you to choose between three different heights of the loading platform. During translation or automatic levelling, the machine will move and keep the selected configuration.

HIGH

Maintain maximum height of the platform from the ground

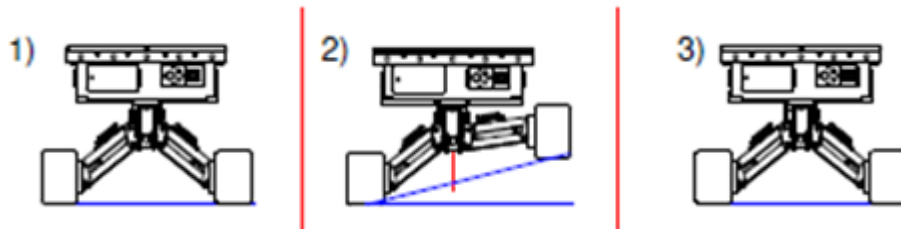

MED

Maintain intermediate height of the platform from the ground

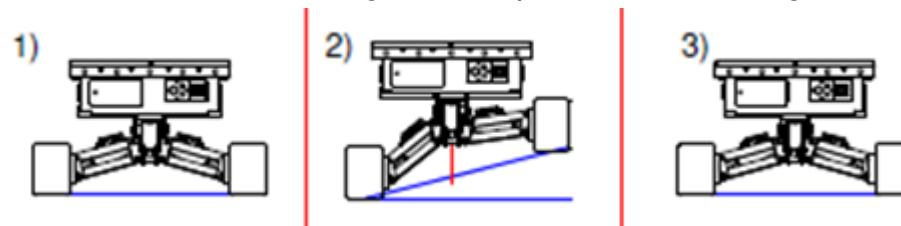

LOW

Maintain minimum height of the platform from the ground

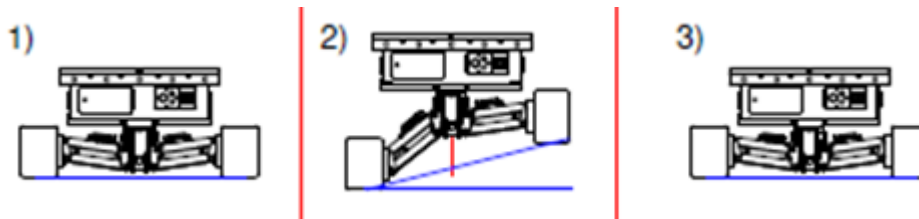

4.3 Positioning of the load on the machine

The machine has been designed and built for loading and moving various materials and/or equipment.

The loading platform has dimensions of 1.11 meters x 2.40 meters, and has a maximum capacity of 2500 kg.



ATTENTION: The load must always be fixed to the machine frame by means of safety straps, to be fixed to the holes present along the entire perimeter of the frame.



ATTENTION: When levelling the vehicle, make sure that the load is not in danger of collision with the surrounding environment.

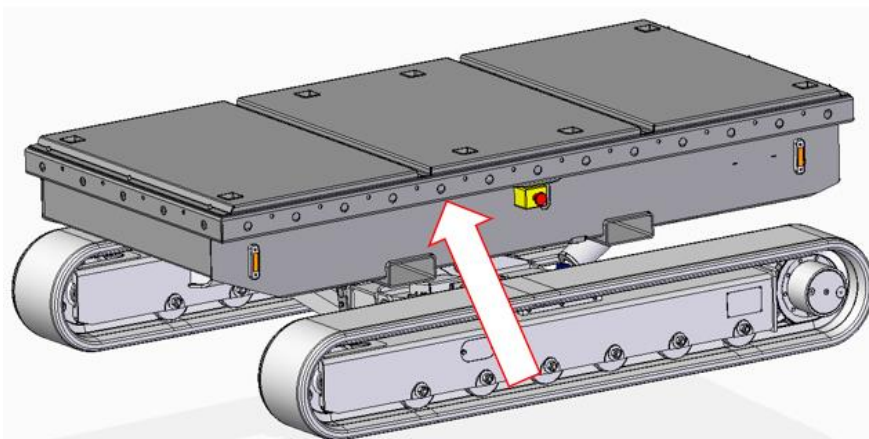

Using the 8 tubular elements in the structure it is possible to use the subframes (not supplied as standard) to support and/or block the loaded material.

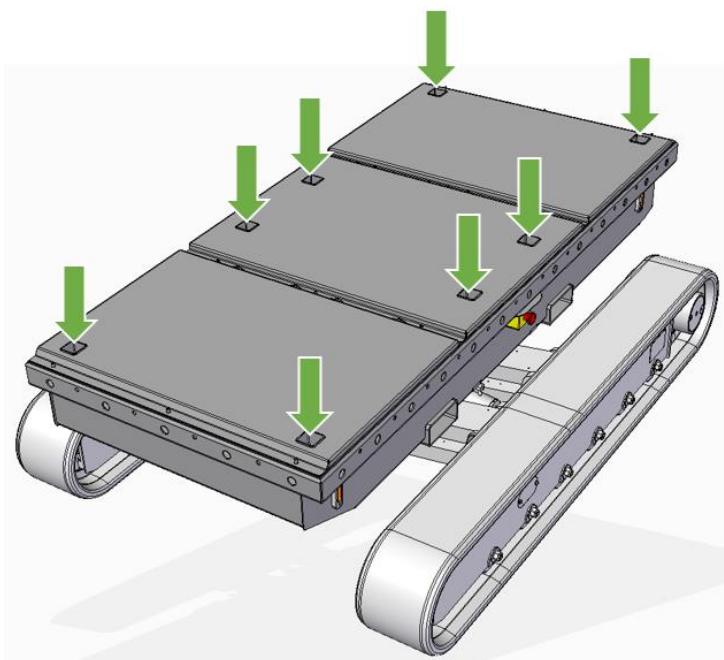

A number of examples follow:







4.4 Messages and alarms on the hour counter



The hour counter located at the back, allows you to view the status of the machine. This display also shows any errors and/or alarms that may occur.



E = operating hours with 220Vac electric motor

e = operating hours with 48Vdc electric motor

In the upper part the charge status of the 48V battery is shown.



rC = percentage of battery charge of the remote controller (battery in the charger)

If there are alarms present, the display will show only the alarm codes.



If there are no alarms at the moment but there were alarms previously (alarms caused by malfunctions that appear intermittently), the service symbol will appear on the display:



The control unit can store up to 16 alarms which are shown by pressing the right button of the hour counter.

These alarms are not cancelled when the machine is turned off.



The table below shows the list of alarm/error codes.

CODE	DESCRIPTION
92	EPROM memory internal error
93	CAN network communication error
40	Frame angle sensor redundancy error
30	Chassis angle sensor redundancy error
41	No signal from the frame angle sensor 1
31	No signal from the chassis angle sensor 1
42	No signal from the frame angle sensor 2
32	No signal from the chassis angle sensor 2
10	No signal from the console
50	Right connecting rod angle sensor redundancy error
80	Left connecting rod angle sensor redundancy error
51	No signal from the right connecting rod angle sensor 1
81	No signal from the right connecting rod angle sensor 2
52	No signal from the left connecting rod angle sensor 1
82	No signal from the left connecting rod angle sensor 2
120	RELAY SHORT CIRCUIT X
121	RELAY SHORT CIRCUIT Z
122	ALARM RELAYS NOT CLOSED

4.5 Quick couplings (if any)

On the right side of the machine are the quick couplings (2), they offer the availability to use any tool with hydraulic supply.

To activate the operation it is necessary to move the AUX selector (1) towards the right (ON), in this way the quick couplings are activated, at the same time all the machine controls are enabled, including translation and self-levelling.

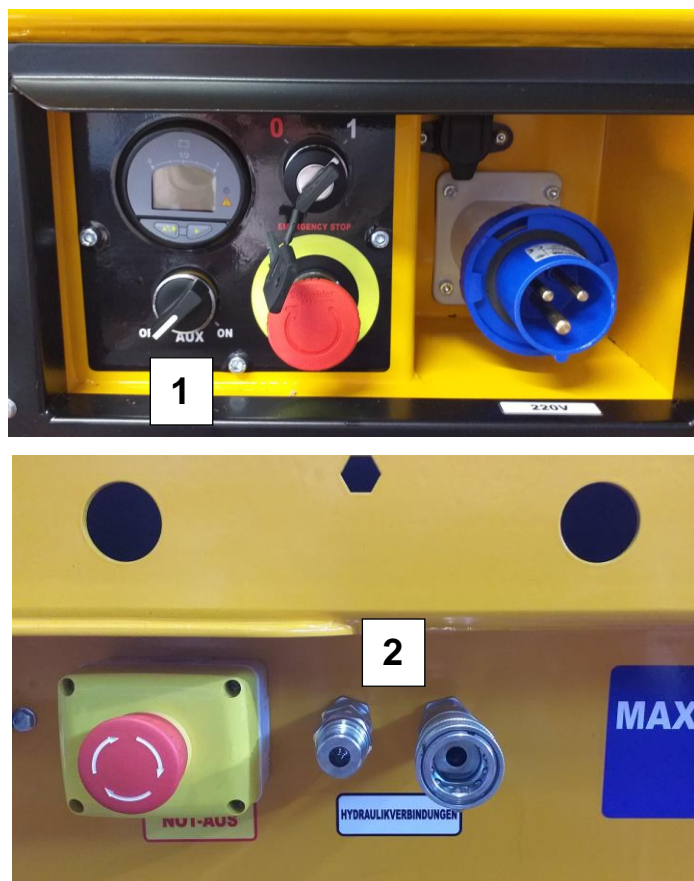

4.6 Stopping the machine

4.6.1 Normal stop

During normal machine use, releasing the TRANSLATION joysticks (9 and 10) stops the movement. Each track installed has a braking system that prevents the machine from moving unless hydraulic pressure is exercised to disengage it.

Deactivation of the machine must take place in these ways:

- Stop the machine in the manner described above;
- Position the key selector (1) on the ground controls in the central position and then remove the key;
- Disconnect the battery from the battery switch (2);
- Place the console in the appropriate compartment (3).

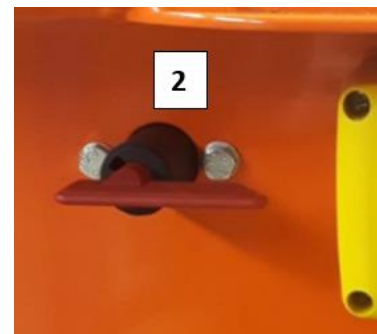
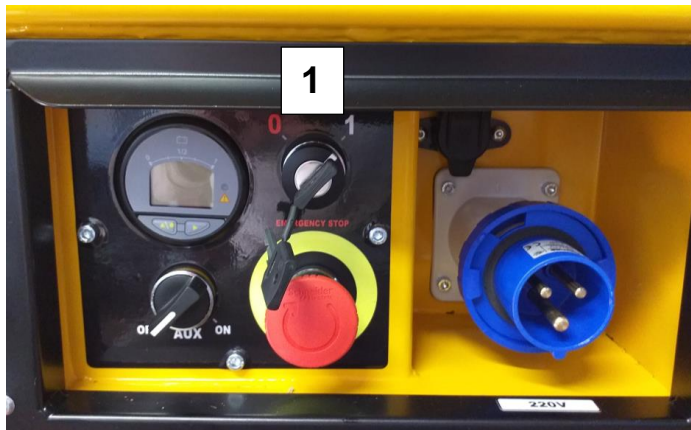

4.6.2 Emergency stop

In abnormal circumstances, or situations in which all machine movements must be stopped, the operator can IMMEDIATELY STOP all the machine functions by pressing the MUSHROOM-SHAPED button on the push-button, or the emergency button place on the GROUND CONTROLS (see figures below).



5 Emergency procedures

5.1 Reception problems with remote control

If the radio control console does not work correctly, it is possible to use the cable supplied (1) to connect it to the machine using the connector (2).



5.2 Transporting the machine in an emergency

To move or transport the machine using external equipment, refer to paragraph 2.5

5.3 Emergency movements from hydraulic block

Warning: this operation must be performed only by qualified technicians trained by Almac S.r.l.

In the event that there is a malfunction of the control unit but it is possible to switch on the electric motor, the movements of the machine can then be performed directly from the hydraulic block.

To perform the movements it is necessary: to release (by turning anti-clockwise) the safety valve 3 and screw (by turning clockwise) the valves 1 and 2 (provided with a lead seal).

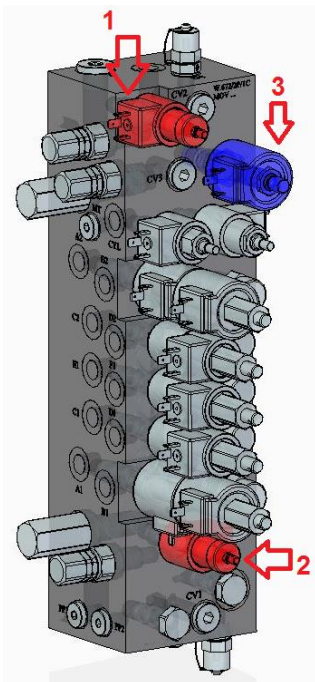

ATTENTION: If valve 3 is not reset to the fully engaged position by pressing and turning clockwise (hear a click) with the valves 1-2 all unscrewed (restore the lead seal), the safety of the machine will be compromised.

ATTENTION: As the operations are performed near the tracks, there is a risk of crushing.

6 Maintenance

6.1 General maintenance

The main maintenance interventions and the frequencies with which they must be carried out are given in the chart below.

6.1.1 Ordinary maintenance schedule table

The checks and maintenance operations must be performed as indicated in the table below.

ORDINARY MAINTENANCE SCHEDULE TABLE	A	B	C	D	E	F	G	H
		10	50	100	250	500	1500	
Visual and functional checks as specified	X							X
Discharge filter cartridge replacement							X	X
Suction filters replacement							X	X
Check the hydraulic oil level	X							X
Change the hydraulic oil							X	
Track reduction gear oil level inspection						X		X
Replace oil in the track reduction gear							X	
Track inspection and tensioning	X							X
Check the condition of the tracks	X							X
Check the tightening of nuts and bolts (general checks)				X				
Check using a torque wrench the tightening of screws and bolts for fixing of the tracked chassis to the machine frame, the screws M16 class8.8 tightening torque 193 Nm (after the first 50 hours)					X			
Structural inspection (visual)	X					X		X
Structural inspection (through checking of metal parts and welds)						X		X
Manual emergency devices	X							X
Check the correct operation of the 230V outlet differential						X		X
Check and replace the fuses					X			X
Check the maximum pressure valve							X	
Check the main system angle sensors	X							X

KEY		
A. Whenever the machine is used	D. monthly or every 100 hours	G. annually or every 1500 hours
B. Daily or every 10 hours	E. every two months or every 250 hours	H. after long periods of inactivity (30 days)
C. Weekly or every 50 hours	F. quarterly or every 500 hours	* Refer to the engine use and maintenance manual



Attention: All maintenance operations must be performed as indicated in *Chapter 2 Information regarding safety*. In particular, maintenance must only be carried out after the emergency push-button has been pressed, the engine turned off and using individual protective equipment.

Attention: Disconnect the machine from all power sources.

Attention: It is mandatory to perform all the machine movements necessary for checks/maintenance.

Note: Use of spurious spare parts, or parts that have not been approved by the manufacturer voids the warranty and relieves ALMAC S.r.l. from all liability.

Note: Modifications or variations to the machine are forbidden unless authorised by the manufacturer.

Note: All maintenance work that is not described in this manual must be authorised by the manufacturer and must be performed by authorised technicians.



Attention: Do not use the machine if one of its mechanical or hydraulic elements or a control or safety device is faulty. Immediately notify Almac S.r.l.

6.1.2 Checks before each use

Prior to commissioning and before each use the machine must undergo the visual and functional checks given below.

The instructions given below must be followed.

VISUAL CHECK	CHECK OPERATION
<ul style="list-style-type: none"> • Make sure that there is no hydraulic oil leaking from the hoses and from the other components (cylinders, distributors, fittings, etc.). • Check that there are no cut or worn electrical cables and that the connectors are correctly secured. • Check the hydraulic oil level. • Make sure that none of the screws, bolts or ferrules are loose or missing. • Make sure that all the pins are in place and correctly secured. • Make sure the tracks are not cut or abnormally worn. • Always check to make sure that track tension is correct. • Check that the manual, the plates and the stickers are on the machine. • Check that the steel structure is not deformed. • Make sure there are no cracks in the welds, damage or abnormal wear. 	<ul style="list-style-type: none"> • Position the machine with the frame inclined to the horizontal with a value greater than 0.5° on the side. Operate the automatic levelling control and make sure that the system automatically keeps the frame horizontal. • Position the machine with the frame inclined to the horizontal by a value greater than 0.5° on the longitudinal. Operate the automatic levelling control and make sure that the system automatically keeps the frame horizontal. • Position the machine with the frame inclined to the horizontal at the maximum angle both on the longitudinal and on the side. Operate the automatic levelling control and make sure that the system automatically keeps the frame horizontal. • Operate the emergency button on the remote control; make sure that the machine is switched off and that no function is permitted. Release the mushroom-shaped button after this test. • Operate the emergency button on the ground, check that the machine is switched off and that no function is possible. Release the mushroom-shaped button after this test. • Operate the emergency buttons on the sides of the machine, make sure that the vehicle is switched off and that no function is permitted. Release the mushroom-shaped button after this test. • Operate the warning buzzer and make sure it works. • Check the operation of the buzzer when the drive function is activated. • Check with the machine in translation (with translation selector in DM) that releasing the Joysticks the machine stops immediately.

6.2 Maintenance: Details

The following points deal with the most significant specific cases

6.2.1 Checking and tightening screws, bolts, plug ring nuts

The operation of the following components must be checked. If necessary, the parts must be tightened with the appropriate tools as indicated in the charts on the following pages.

Clamping forces and tightening torque for bolts with a normal stroke metric thread (use the **Max** torque)

Resistance class in accordance with DIN/ISO 898			8.8		
Yielding point Rp 0,2 N/mm ²			640 for ≤ M16 / 660 for ≥ M16		
Metric thread ISO	Cross-section of the powered zone	Cross section of the thread	Clamping force	For hydraulic and electrical torque wrench	Max = 0.9 MD* for the wrench
DIN 13	AS mm ²	A3 mm ²	FM [kN]	MA [Nm]	MA' [Nm]
M12	84.3	76.2	38.5	87	78
M14	115	105	72	140	126
M16	157	144	91	215	193
M18	193	175	117	300	270
M20	245	225	146	430	387
M22	303	282	168	580	522
M24	353	324	221	740	666
M27	459	427	270	1100	990
M33	561	519	335	1500	1350
M36	694	647	395	Bolt determined by measuring the yielding	
M39	817	759	475		
M42	976	913	542		

6.2.2 Visual and structural inspection

Visually check the following points according to the schedule indicated in the general chart. Immediately inform a maintenance technician if faults are discovered.

- Frame state;
- State of the bi-levelling structure and of the tracked chassis;
- In particular check if there is any rust in the structure;
- State of the rubber tracks;
- Oil leaking;
- Pins and stop devices.

6.2.3 Damage to tubes and cables

Visually check at the frequencies indicated in the general chart to make sure that the articulation point of the hydraulic hoses and electric cables are not misshapen or damaged. Examples of such faults are shown on the photos below.



Damaged hydraulic hose pipe



Damaged electric cable

6.2.4 Checking the hydraulic tank oil level and topping up if necessary

The hydraulic oil level is checked by means of a level indicator located directly on the tank.



6.2.5 Hydraulic reservoir oil change

The hydraulic oil in the tank must be changed with the frequency indicated in the general chart.

1. Collect the used oil in a suitable vessel and dispose of it in the proper way.
2. Empty the tank using the dedicated cap located under the tank (1).

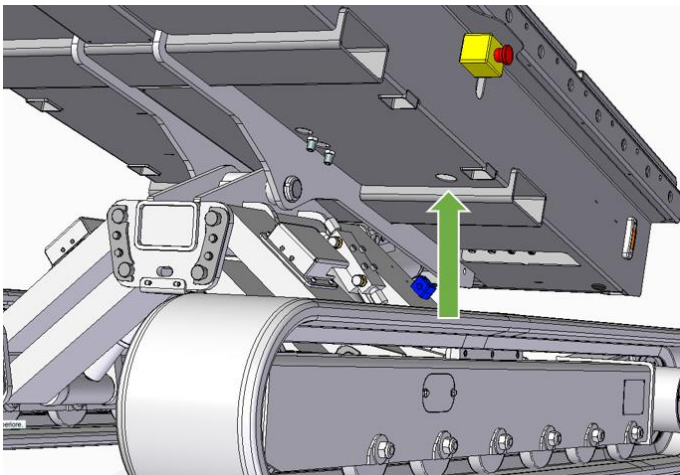

Attention: DO NOT
DISPERSE USED OIL INTO
THE ENVIRONMENT. USE
SPECIAL COLLECTION.

6.2.6 Checking the operation of the maximum pressure valves

With the frequency indicated in the general chart, check the operation of the maximum pressure valves of the distributor.

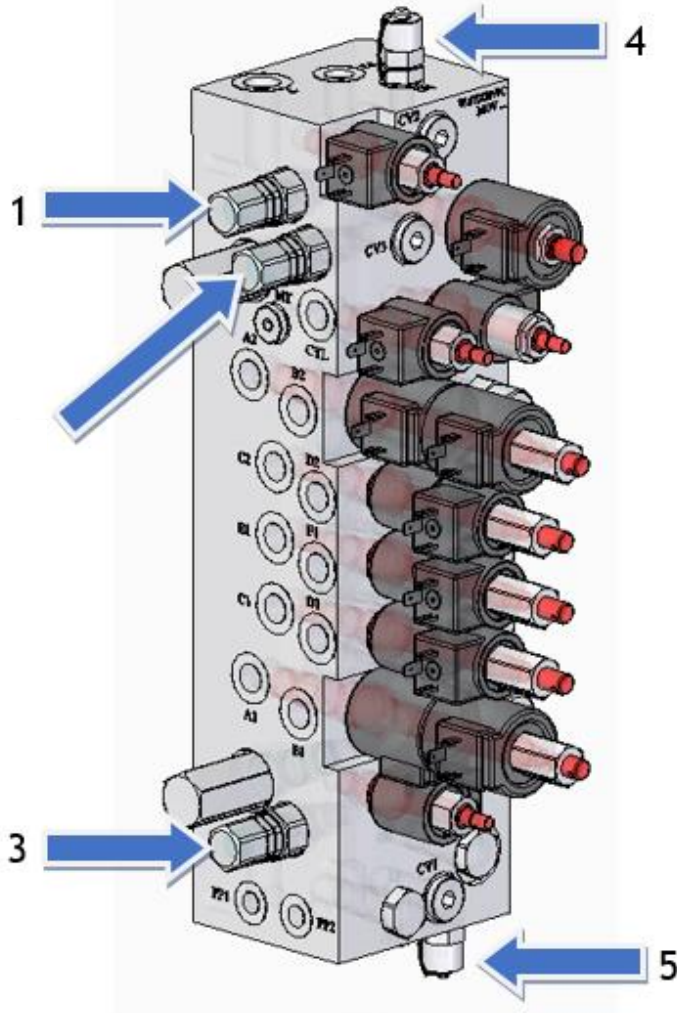

To test them, connect two pressure gauges with a full scale of 250 bar to the pressure outlets supplied (4 and 5).

Checking the general maximum pressure valves of the system (1 and 3)

The pressure gauges relating to these valves are those connected to the outlets 4 and 5.

- a) Start the machine;
- b) Perform the levelling movements until the limit switch has been reached and keep them in this position for a few seconds. This activates the maximum pressure valve of the circuit;
- c) Read the pressure on the gauge, which should be 220 bar \pm 5 bar.

The valves are calibrated during the testing phase performed by ALMAC S.r.l. and should not require further adjustment unless:

- the hydraulic circuit is replaced;
- the actual pressure relief valve is replaced.

In these cases, the valve must be calibrated by SPECIALIST PERSONNEL according to the monitoring procedure described above. Using the appropriate tools, unscrew the lock nut (1) and tighten or loosen the adjuster screw (2) until the indicated pressure level has been reached. Once the adjustments have terminated, tighten the lock nut (1) to hold the screw in position.

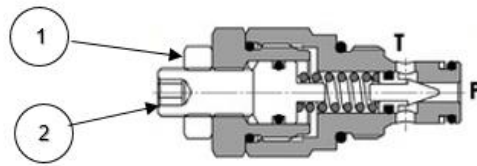

Diagram of the pressure relief valve



Attention: calibration operation must only be performed by SPECIALIST personnel. It must not be performed by a generic operator.

6.2.7 Hydraulic filter replacement

Replace the discharge filters of the hydraulic circuit at the frequencies indicated in the general chart.

The hydraulic oil tank features:

- No.2 intake filters inside the tank (1)
- 1 discharge filter in the top part of the tank (2).

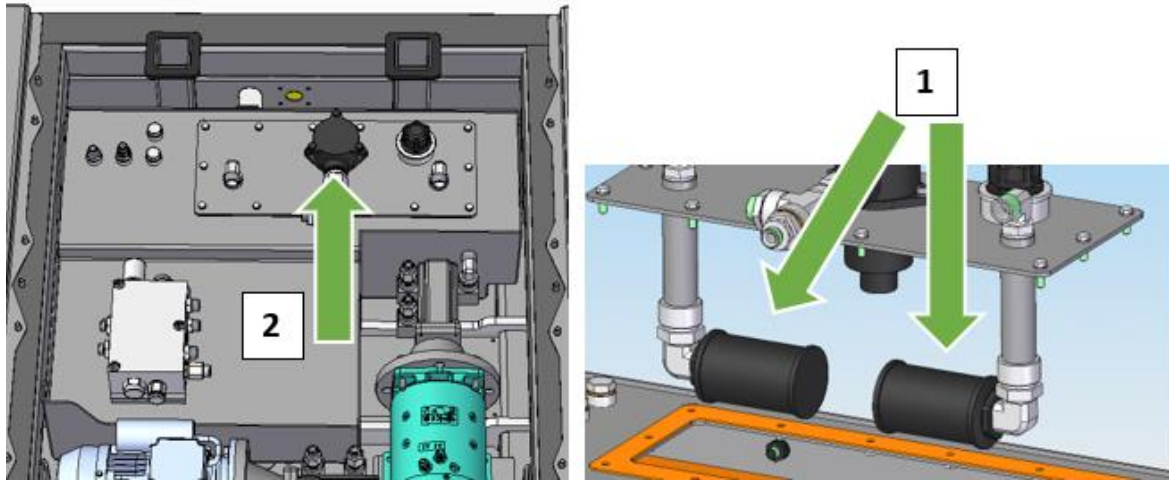

6.2.7.1 Suction filters replacement

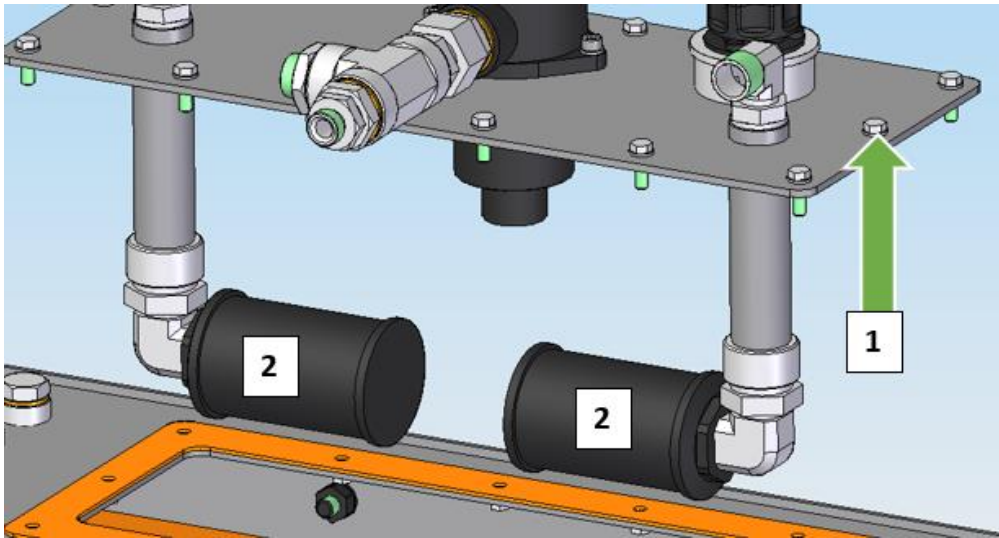

To replace the intake filters located inside the hydraulic tank, proceed as follows:

- 1) Remove the central filling platform;
- 2) Empty the hydraulic oil tank;
- 3) Unscrew the blocking screws (1) on the hydraulic tank lid and remove it from its housing;
- 4) Remove filter (2) and replace it with a new one;
- 5) Work through the instructions above in reverse order to restore the machine to its normal operating conditions;
- 6) Seal the lid with sealing paste;
- 7) Fill the hydraulic oil reservoir with oil and check the level.

6.2.7.2 Replacing the discharge filter

To replace the discharge filter located above the hydraulic tank, proceed as follows:

- 1) Remove the central filling platform;
- 2) Unscrew the blocking screws (1) on the filter and remove it from its housing;
- 3) Unscrew the filter cartridge (2), being careful with the seals and/or O-rings;
- 4) Remove the cartridge (3) and fit a new one in its place;
- 5) Work through the instructions above in reverse order to restore the machine to its normal operating conditions.

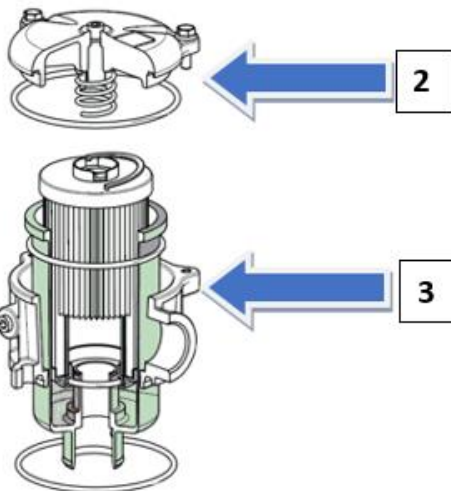
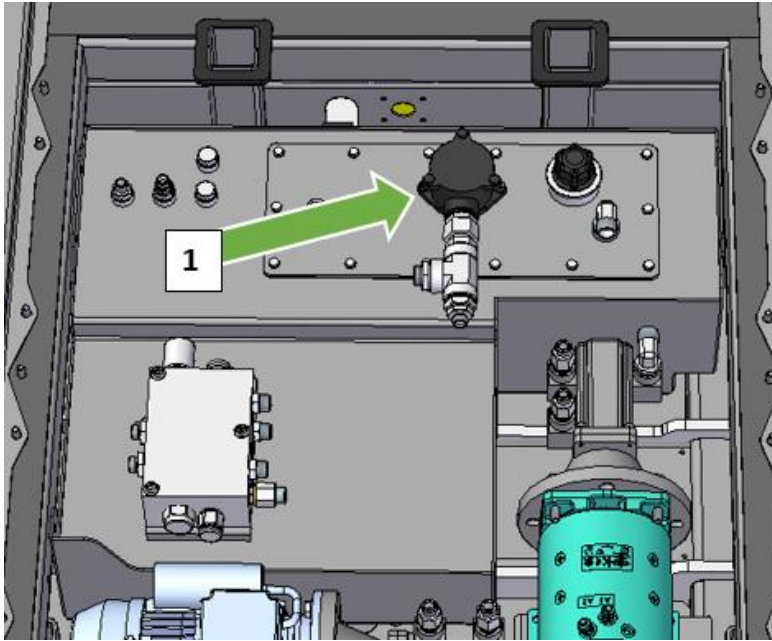

Attention: during operations some oil could spill. Remove spilt oil with a cloth or place a vessel underneath so that the oil drains into it.

ONLY USE GENUINE SPARE PARTS when replacing the filters. Contact the **ALMAC** technical assistance service.

Do not reuse used oil. Do not dispose of it in the environment. Used oil must be disposed of as required by the laws in force.

6.2.8 Traction batteries (Type:Lead Crystal)

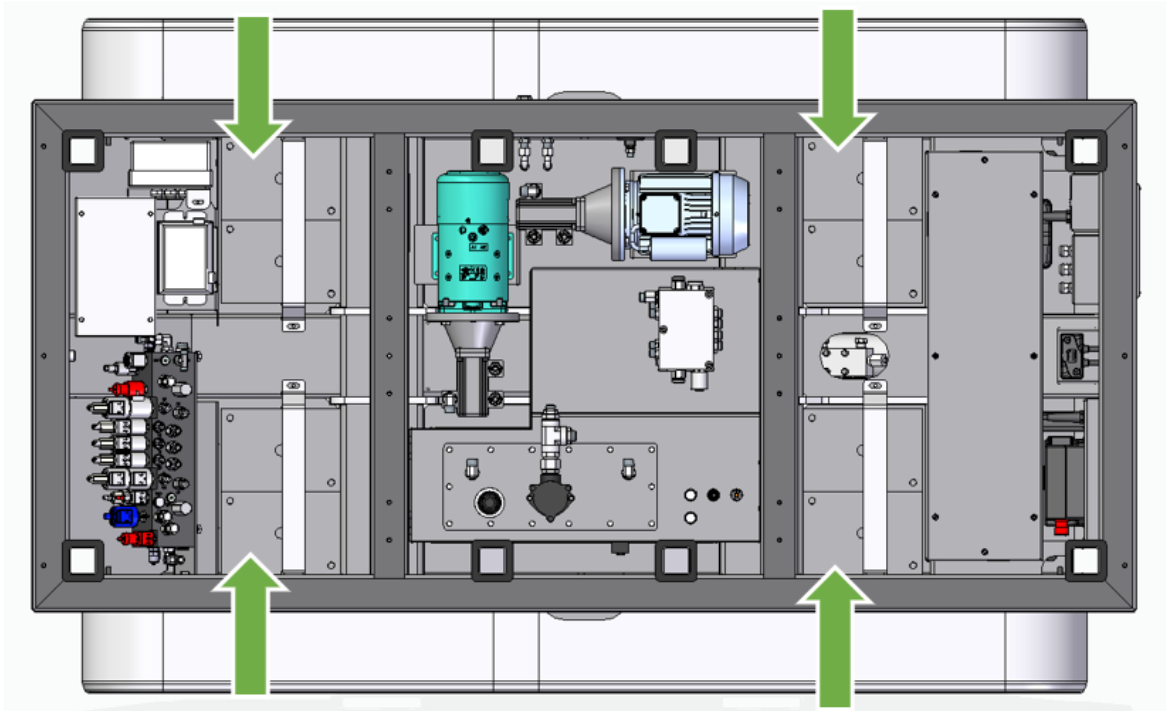

6.2.8.1 General warnings

The battery is an essential component for machine operation. It is important to ensure that it remains in a good condition over time since this will lengthen its working life, limit any problems that may arise and reduce the running costs of the machine.

Comply with the following instructions:

- THE INSTALLATION IS PERFORMED BY THE MACHINE CONSTRUCTOR, IN ACCORDANCE WITH THE INSTRUCTIONS AGREED WITH THE SUPPLIER'S TECHNICAL SUPPORT;
- CAREFULLY READ THE INSTRUCTIONS FOR USE AND MAINTENANCE BEFORE PERFORMING ANY OPERATION WITH THE BATTERY;
- AN IMPROPER USE OF THE BATTERY, OR SHORT CIRCUIT BETWEEN THE POLES, OVERHEATING, NEXT TO NAKED FLAMES OR SPARKS, CAN CAUSE SERIOUS DANGERS;
- DO NOT EXPOSE THE BATTERY TO HEAT OR FIRE OR MICROWAVES;
- DO NOT INSERT ANY METALLIC OBJECT INTO THE BATTERY COMPARTMENT;

- DO NOT DEPOSIT THE BATTERY TOGETHER WITH HIGH METALLIC OBJECTS (SUCH AS THE TOOL BOX) OR TOGETHER WITH OTHER BATTERIES. DANGER TO GENERATE A SHORT CIRCUIT ELECTRIC;
- PLACE BATTERIES AND ELECTRICAL APPLIANCES OUT OF THE REACH OF CHILDREN.

6.2.8.2 Maintenance

The batteries chosen by Almac S.r.l. require limited maintenance. Keep the batteries charged, if possible, 100%. Also, perform this simple series of operations periodically:

- Check the cables, the clamps, and if there is obvious damage or loose connections;
- Clean the terminals and connectors if necessary;
- Recharge the system every 3-4 weeks if the vehicle is left stationary for long periods without disconnecting the electrical system cables;
- If you disconnect the battery from the vehicle's electrical system, you must however recharge it periodically every 2-3 months, and above all fully recharge the battery before restarting the vehicle and before storing the battery for long periods of time.



Attention: Always wear a visor or goggles when operating on the battery.
Wear plastic gloves, an apron or overall to protect your clothes.
Remove bracelets, rings or other metal objects that could cause short involuntary circuits.

In case of uncertainty, contact ALMAC technical assistance

6.2.8.3 Recharging

The batteries are recharged by connecting to the 110V or 220V mains power supply.

Do not charge the batteries with current values higher than those indicated in the technical specifications and recommended in the instructions, it could cause dangerous overheating and a drastic reduction in the life of the battery series.

The Lead Crystal batteries must be recharged mainly by enabling both battery chargers (40A). The use of the single battery charger must always take place in cases of extreme necessity and occasionally.

Attention!! Continuously using only one 20A charger will damage the batteries.

The Lead Crystal batteries can be recharged only with the battery chargers on board the machine, in case of a different charging system, contact ALMAC company for authorisation.



NEVER SMOKE, CREATE SPARKS OR FLAMES NEAR BATTERIES AND BATTERY CHARGERS: EXPLOSION RISK.

6.2.8.4 Battery storage

Recharge the battery at least every three to four months.

In the event of prolonged immobilisation, charge 100% before storage and before re-use. In all cases, the storage and maintenance recharges must be performed through the use of the battery chargers on board the machine and both must be enabled.

Make sure the batteries are stored in areas out of the reach of children.



DO NOT USE CHARGE MAINTENERS, BATTERY TENDERS, FAST CHARGERS OR OTHER SIMILAR DEVICES. ONLY USE THE BATTERY CHARGER PROVIDED.

DO NOT CHARGE THE BATTERY BEYOND THE MAXIMUM VOLTAGE INDICATED.

Check the external status of the terminals and casing for any signs of damage or abnormal wear which may have occurred during service. If in any doubt about the condition of the battery, it is advisable to contact the machinery manufacturer.



**DO NOT WASH OR IMMERSE THE BATTERY IN WATER OR OTHER LIQUIDS:
SHORT CIRCUIT RISK.**

6.2.9 Checking the operation of the frame angle sensor

With the frequency indicated in the general chart, check the frame angle sensor.



- Position the machine with the frame inclined to the horizontal with a value greater than 0.5° on the side. Operate the automatic levelling control and make sure that the system automatically keeps the frame horizontal;
- Position the machine with the frame inclined to the horizontal by a value greater than 0.5° on the longitudinal. Operate the automatic levelling control and make sure that the system automatically keeps the frame horizontal;
- Position the machine with the frame inclined to the horizontal at the maximum angle both on the longitudinal and on the side. Operate the automatic levelling control and make sure that the system automatically keeps the frame horizontal.

If the operations described above take place in the indicated sequence, it means that the angle sensor is working properly.

Warning: if the conditions indicated above are not met, do not use the machine and contact a qualified technician trained by Almac S.r.l.

6.2.10 Verification of the chassis angle sensor function

With the frequency indicated in the general chart, check the frame angle sensor.

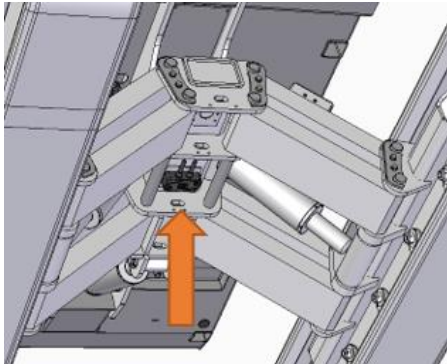

- Position the machine with the frame inclined to the horizontal by a value greater than 0.5° on the longitudinal. Operate the automatic levelling control and make sure that the system automatically keeps the frame horizontal;
- Position the machine with the frame inclined to the horizontal at the maximum angle both on the longitudinal and on the side. Operate the automatic levelling control and make sure that the system automatically keeps the frame horizontal.

If the operations described above take place in the indicated sequence, it means that the angle sensor is working properly.

Warning: if the conditions indicated above are not met, do not use the machine and contact a qualified technician trained by Almac S.r.l.

6.2.11 Checking the differential circuit breaker

With the frequency indicated in the general chart, check the differential circuit breaker

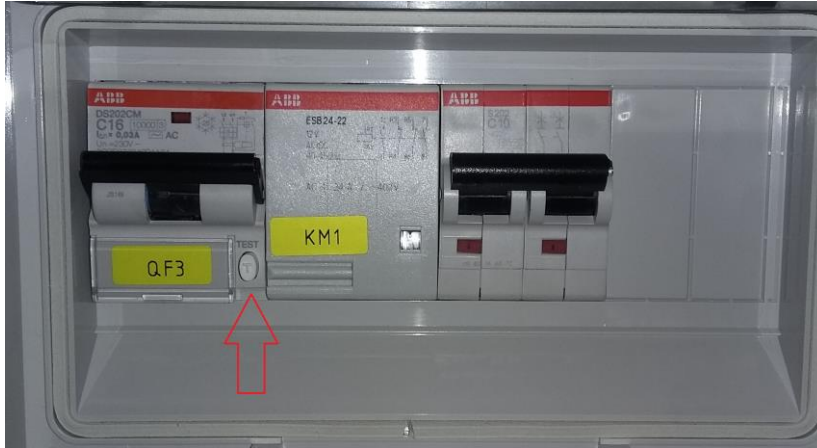

Connect the plug in the ladder to an electric power supply that conforms to the following specifications:

- Voltage: 230 v \pm 10%
- Frequency: 50 Hz
- Grounding line working and equipped with a differential circuit breaker
- Use an extension power cord with an appropriate section depending on its length

Press the button indicated in the figure and make sure that the differential switch is triggered.

6.2.12 Check the seal of the chassis balancing valves

Attention: this test must only be performed by qualified technicians authorised by Almac S.r.l.

With the frequencies indicated in the general table, check the tightness of the flanged valves on the cylinders.

To perform this check, it is necessary to:

- 1) Position the machine as shown in the figure (chassis fully raised)
- 2) Position 2500 Kg as shown in the figure

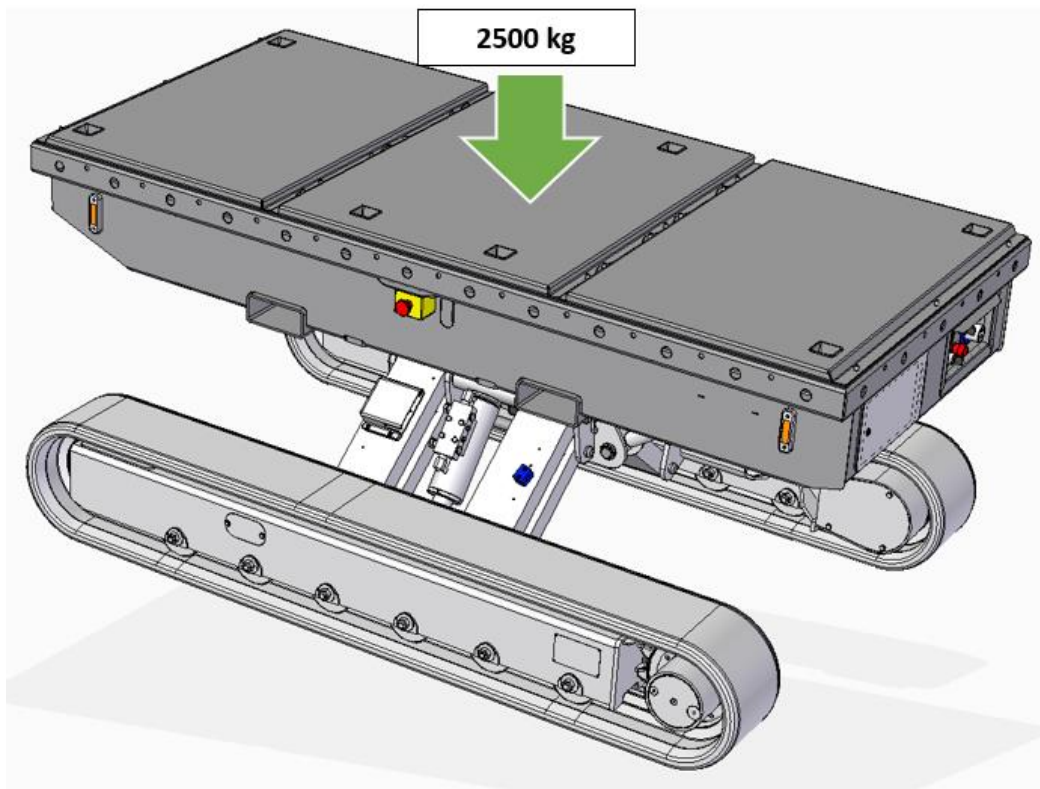

- 3) Make sure that the machine remains in the position where it was left and that there have been no movements due to oil leaking from the valves (due to a malfunction or impurities trapped in the cursor).

6.2.13 Track inspection and tensioning

Check track tension at the inspection frequency indicated in the general chart.

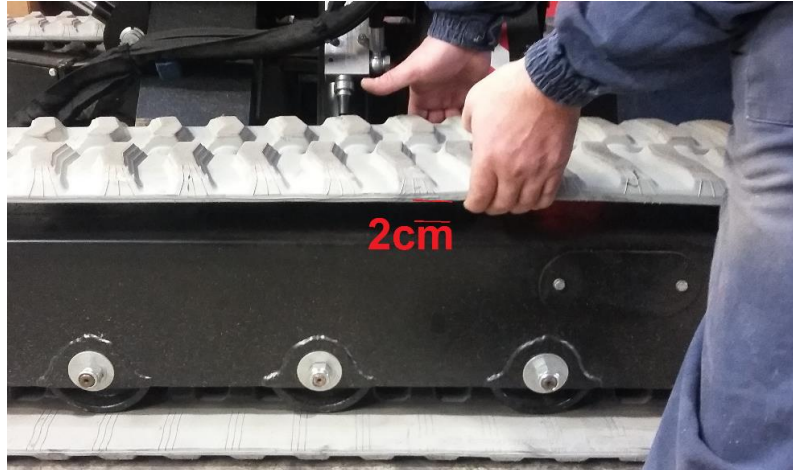

Pull the track slightly upwards in correspondence with the centre line; the deformation must be of approximately 2 cm.

If the track sags and becomes too noisy as it moves, it must be tightened as described below:

- 1) Remove the guards (1)
- 2) For correct track tension, use a tensioning kit (2), not included in the supply, and pump grease into the tensioning valve (3) until the pressure indicated below is reached. Consult the grease chart on the next pages for the type of grease required.

Max pressure for track tensioning	Bar	300
-----------------------------------	-----	-----

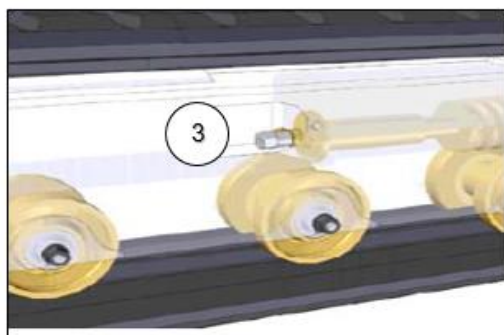
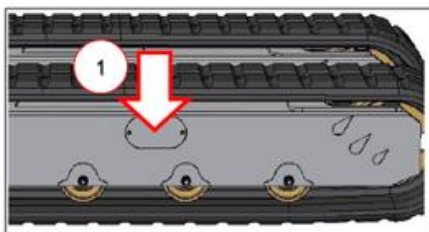

GREASES TABLE	
(The grease normally used by the manufacturer is PAKELO)	
Grease	°C -10 / 40
PAKEL0	BEARING EP GREASE NLG12
BP	GREASE LTX2
CASTROL	LM2 - SPEEROL APT2
SHELL	ALVANIA GR.R.2
ESSO	BEACON 2
SMALL VALVES	LITHIUM 20
ELF	TRASLUBE LI GREASE 2

6.2.14 Checking the tracks for wear

Check the wear and condition of the tracks, replacing them when the tread is equal to or less than 10 mm.

The tracks must be changed even before they reach this limit if they are cuts or tears are noted.



Tracks must only be replaced by specialized, properly trained personnel. Follow the “track replacement” procedure illustrated on the following pages.

6.2.15 Replacing the tracks



WARNING: it is forbidden to open the reducer for any operation not provided for by scheduled maintenance. The manufacturer shall not be held responsible for any operations not included in scheduled maintenance that have caused damage to property and/or harmed people.

WARNING: USE PERSONAL PROTECTIVE DEVICES

Replacing the track

The track must be replaced when 10 mm of tread is left or even earlier if there are any cuts. Proceed as follows:

1. Do not lift the machine from the ground excessively (15-20 cm are enough).



WARNING: make sure that the machine is stable.

2. Thoroughly clean all the parts of the undercarriage.
3. Remove the side closure of the longeron (1).

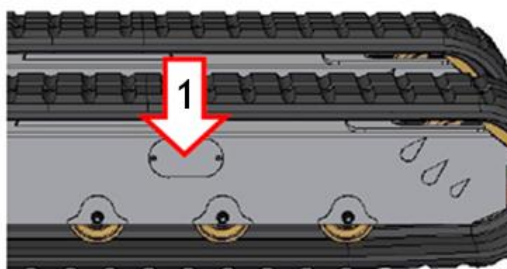

4. Loosen the tensioning valve (2).
5. Remove the tensioning valve only when it is no longer under pressure.

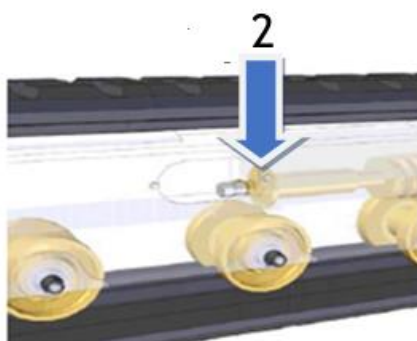

6. Using the nut supplied (point A).

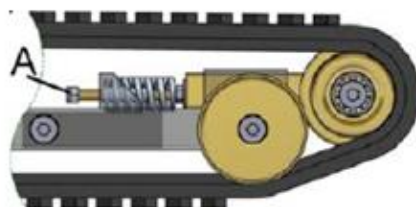

7. Move the front wheel back by pressing on the track with your foot.

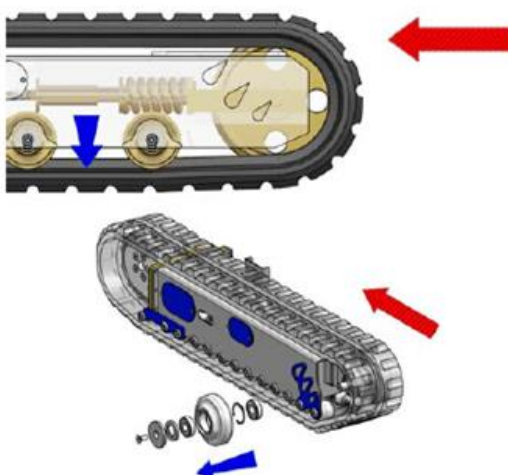



ATTENTION: BE CAREFUL WHEN THE TRACK FALLS TO THE GROUND.

1. Lift the track at the lower centre line;
2. Pull the track (outwards), prying between the track itself and the idler wheel;
3. To install the new track, proceed as indicated in the previous points, but in reverse order;
4. The track is correctly tensioned by using the tensioning kit, pumping grease until the pressure indicated on the technical data sheet has been reached.



WARNING: before performing the tensioning of the track, check the technical data sheet for the correct pressure expressed in bar.

6.2.16 Track reduction gear oil level inspection

Check the level of the oil in the track reduction gears at the frequencies given in the general chart. Comply with the procedure described below.

This model features dual displacement gear motors with gears in oil bath. It is very important to periodically check the oil level (frequency indicated in the scheduled maintenance and checks table).

- 1- Move until the gear motor is in the condition in which the "FILL" cap is at the top, and perpendicular to the "DRAIN" cap.
- 2- To drain the oil:
 - a. Unscrew the FILL cap;
 - b. Unscrew the LEVEL cap.
- 3- Once the gear unit has been emptied, translate until the geared motor moves to the condition in which the "FILL" plug is at the top and perpendicular to the "DRAIN" plug.
- 4- To top up the oil:
 - a. using a syringe, add oil through the FILL cap, until the oil comes out of the LEVEL cap.
- 5- Screw the LEVEL cap back on.
- 6- Screw the FILL cap back on.

USE Shell SPIRAX S3 AX 80W/90 OIL

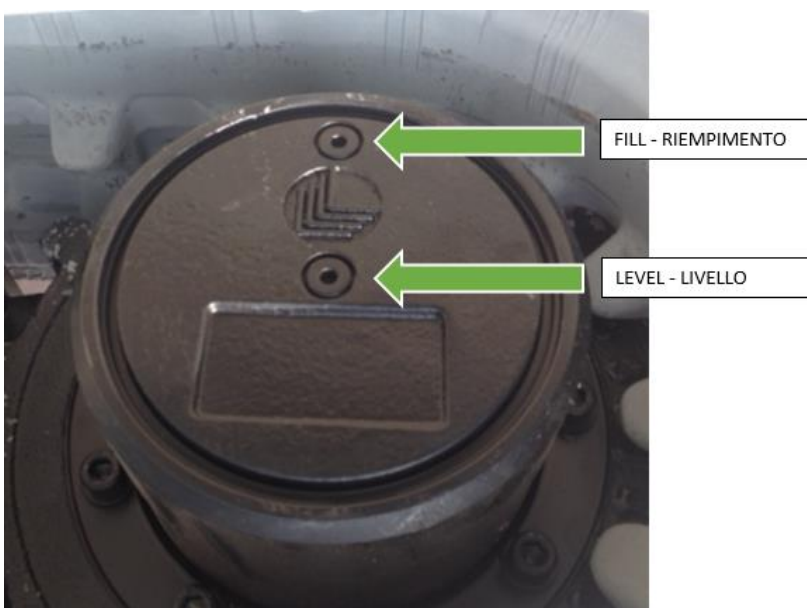

7 Demolition

7.1 Machine life

The machine has been designed to work for 10 years in normal operating environments considering proper use and correct maintenance.

7.2 Decommissioning and demolition

Once the machine has reached the end of its technical and operational life, it must be subjected to a detailed and complete inspection/review by the manufacturer or specialised and qualified technicians. If the test does not have a positive outcome, the equipment must be deactivated and demolished. The machine must be reduced to conditions in which it can no longer be used for the purposes for which it was designed and built. In addition, the raw materials used to make it must be recovered for recycling purposes where possible.



Note: ALMAC S.r.l. declines all liability for damage to persons, animals or things deriving from reuse of parts of the equipment for functions or assembly situations differing from the original ones.



Danger: Machine decommissioning and demolition must be carried out only by properly trained and equipped personnel.

The machine must be demolished following the adoption of safety measures that must take account of the logistic, environmental and wear conditions of the machine itself.

Comply with the following general rules:

- wear approved protective clothing and accessories (hard-hat, safety footwear, gloves, goggles and face mask if necessary) in accordance with the accident-prevention laws in force.
- Disconnect the machine from all power sources.
- Check and, if necessary, relieve the pressure from pressurized systems.

- Ensure that the machine is unable to operate and that it cannot be used, by breaking some of its vital components and take it to a place where you are certain that it cannot be accessed by anyone.
- Use appropriate lifting devices.
- Disassemble the machine into small, easily transportable units.
- Separate non-polluting materials from polluting ones when disposing of the machine (insulating materials, plastic, rubber, etc.)
- Never burn the machine or parts of it because the combustion products of plastic materials and paints could develop harmful, polluting gases.

7.3 Battery disposal

Battery recycling is mandatory (European Directive 2006/66/EC) and recommended.

- Cells and batteries, even if fully discharged, may still contain a considerable amount of energy. It is therefore necessary to always protect the terminals to prevent short circuits.
- Dispose of the batteries in compliance with local laws and regulations (contact your nearest dealer).
- Keep the material to be disposed of as indicated in the specific Section of the Safety Data Sheet attached.
- DO NOT throw into sewers, on the ground or in water courses.

8 ATTACHMENTS

8.1 Declaration of conformity (FAC-SIMILE)

 <p>ALMAC CRAWLER S.r.l.</p>	
<p>Declaration of Conformity</p> <p><i>Original declaration</i></p>	
<p>ALMAC S.r.l. Viale Ruggeri 6/a c.a.p. 42016, Guastalla (RE) - Italia Tel 0522-1495846 http: www.almac-italia.com e-mail: info@almac-italia.com P.IVA e Cod.Fisc. 02559800350</p>	
<p>Declares, under our own responsibility that the machine:</p>	
MODEL:	MULTI-LOAD 2.
SERIAL NUMBER:	ALM-01
MANUFACTURING YEAR:	20
<p>as described in the documentation attached to this declaration is in accordance with:</p> <ul style="list-style-type: none"> • Directive 2006/42/EC on machinery • UNI EN ISO 12100:2010 Safety of machinery - Risk assessment - Principles • Directive 2014/30/UE on the approximation of the laws of the Member States relating to electromagnetic compatibility • Directive 2000/14/EC (rev. V) on the emission in the environment by equipment for use outdoors 	
<p>The Legal representative of the constitution of the Technical Dossier is:</p>	
Name:	PIETRO
Surname:	AGOSTA DEL FORTE
Position:	Legal representative of ALMAC s.r.l.
<p>FAC-SIMILE</p>	
<p><u>Guastalla (RE), li 09/04/2018</u></p> <p>(Place and Date)</p>	<p><u>PIETRO AGOSTA DEL FORTE</u> (Legal representative)</p> <p>(Stamp and Signature)</p>

8.2 Report register

Report register

The Report register is issued to the platform user with reference to:

- Legislative Decree 17/2010 - Implementation of Machinery Directive 2006/42/EC

The purpose of this Register is to record events concerning the life of the machine; in detail:

- Mandatory routine inspections (INAIL, ASL, authorised bodies).
- Maintenance and obligatory inspections to check the integrity and structure of the machine and protection and safety systems.
- Transfers of ownership, to be notified to the competent INAIL (former ISPESL) department.
- Supplementary maintenance or replacement of important parts of the machine.

Type of inspection		Description	
Checking and tightening screws, bolts, plug ring nuts			
	Date	Observations	Signature
1st year			
2nd year			
3rd year			
4th year			
5th year			
6th year			
7th year			
8th year			
9th year			
10th year			

NOTE: frequency of the operation as indicated in the table in Chapter 6. Daily registration is not necessary, but should be made at least once a year when other operations are performed.

Type of inspection		Description	
Visual and structural inspection		Check the integrity of the anchors, supports, carpentry, welding and pins	
	Date	Observations	Signature
1st year			
2nd year			
3rd year			
4th year			
5th year			
6th year			
7th year			
8th year			
9th year			
10th year			

NOTE: frequency of the operation as indicated in the table in Chapter 6. Daily registration is not necessary, but should be made at least once a year when other operations are performed.

Type of inspection		Description	
Damage to tubes and cables			
	Date	Observations	Signature
1st year			
2nd year			
3rd year			
4th year			
5th year			
6th year			
7th year			
8th year			
9th year			
10th year			

NOTE: frequency of the operation as indicated in the table in Chapter 6. Monthly registration is not necessary, but should be made at least once a year when other operations are performed.

Type of inspection		Description	
Hydraulic tank oil level inspection			
	Date	Observations	Signature
1st year			
2nd year			
3rd year			
4th year			
5th year			
6th year			
7th year			
8th year			
9th year			
10th year			

NOTE: frequency of the operation as indicated in the table in Chapter 6. Daily registration is not necessary, but should be made at least once a year when other operations are performed.

Type of inspection		Description	
Hydraulic reservoir oil change			
	Date	Observations	Signature
1st year			
2nd year			
3rd year			
4th year			
5th year			
6th year			
7th year			
8th year			
9th year			
10th year			

NOTE: frequency of the operation as indicated in the table in Chapter 6.

Type of inspection		Description	
Check the operation of the maximum pressure valve			
	Date	Observations	Signature
1st year			
2nd year			
3rd year			
4th year			
5th year			
6th year			
7th year			
8th year			
9th year			
10th year			

NOTE: frequency of the operation as indicated in the table in Chapter 6.

Type of inspection		Description	
Hydraulic filter replacement			
	Date	Observations	Signature
1st year			
2nd year			
3rd year			
4th year			
5th year			
6th year			
7th year			
8th year			
9th year			
10th year			

NOTE: frequency of the operation as indicated in the table in Chapter 6.

Type of inspection		Description	
Lead Crystal battery status verification			
	Date	Observations	Signature
1st year			
2nd year			
3rd year			
4th year			
5th year			
6th year			
7th year			
8th year			
9th year			
10th year			

NOTE: frequency of the operation as indicated in the table in Chapter 6.

Type of inspection		Description	
Check the operation of the angle sensors			
	Date	Observations	Signature
1st year			
2nd year			
3rd year			
4th year			
5th year			
6th year			
7th year			
8th year			
9th year			
10th year			

NOTE: frequency of the operation as indicated in the table in Chapter 6.

Type of inspection		Description	
Check the operation of the differential switch of the 230V outlet			
	Date	Observations	Signature
1st year			
2nd year			
3rd year			
4th year			
5th year			
6th year			
7th year			
8th year			
9th year			
10th year			

NOTE: frequency of the operation as indicated in the table in Chapter 6.

Type of inspection		Description	
Track inspection and tensioning			
	Date	Observations	Signature
1st year			
2nd year			
3rd year			
4th year			
5th year			
6th year			
7th year			
8th year			
9th year			
10th year			

NOTE: frequency of the operation as indicated in the table in Chapter 6. Daily registration is not necessary, but should be made at least once a year when other operations are performed.

Type of inspection		Description	
Track inspection and replacement			
	Date	Observations	Signature
1st year			
2nd year			
3rd year			
4th year			
5th year			
6th year			
7th year			
8th year			
9th year			
10th year			

NOTE: frequency of the operation as indicated in the table in Chapter 6.

Type of inspection		Description	
Track reduction gear oil level inspection			
	Date	Observations	Signature
1st year			
2nd year			
3rd year			
4th year			
5th year			
6th year			
7th year			
8th year			
9th year			
10th year			

NOTE: frequency of the operation as indicated in the table in Chapter 6. Daily registration is not necessary, but should be made at least once a year when other operations are performed.

Type of inspection		Description	
Parking brake		Make sure that parking brake functions correctly when machine stops	
	Date	Observations	Signature
1st year			
2nd year			
3rd year			
4th year			
5th year			
6th year			
7th year			
8th year			
9th year			
10th year			

NOTE: frequency of the operation as indicated in the table in Chapter 6. Registration every six months is not necessary, but should be made at least once a year when other operations are performed.

Serious faults		
Date	Description of fault	Solution
Spare parts used		Description
Code	qty	

Serious faults		
Date	Description of fault	Solution
Spare parts used		Description
Code	qty	

Serious faults		
Date	Description of fault	Solution
Spare parts used		Description
Code	qty	

8.3 Property transfers

<i>Copy to be kept</i>	
on:	
the machine properties:	
serial no.	
year of manufacture	
was transferred to:	
It is hereby certified that, as of the date above, the technical, dimensional and functional characteristics of the aforementioned platform conformed to the original characteristics and that variations, if any, have been recorded in the register.	
Seller's business name:	
Seller	
Purchaser	

<i>Copy to be spent to ALMAC S.R.L.</i>	
on:	
the machine properties:	
serial no.	
year of manufacture	
was transferred to:	
It is hereby certified that, as of the date above, the technical, dimensional and functional characteristics of the aforementioned platform conformed to the original characteristics and that variations, if any, have been recorded in the register.	
Seller's business name:	
Seller	
Purchaser	

8.4 *Hydraulic diagram*

See attachment

8.5 *Wiring diagram*

See attachment

9 INDEX

1	GENERAL INFORMATION	2
1.1	DOCUMENTS SUPPLIED WITH EACH MACHINE	2
1.2	DETAILS OF MANUAL	2
	<i>RECIPIENTS OF THIS MANUAL</i>	2
1.3	OWNERSHIP OF THE INFORMATION	3
1.4	MANUFACTURER'S IDENTIFICATION DATA	3
1.5	IDENTIFICATION DATA.	4
1.6	PERFORMANCE	5
1.7	CE DECLARATION OF CONFORMITY	8
1.8	WARRANTY	8
	1.8.1 <i>Request for interventions during warranty period and formalities</i>	9
1.9	ASSISTANCE	9
	1.9.1 <i>Request for assistance and repairs</i>	9
1.10	USE OF THE MANUAL	10
1.11	INTENDED USE AND IMPROPER USES	11
	1.11.1 <i>Intended use</i>	11
	1.11.2 <i>Improper uses</i>	12
	1.11.3 <i>Cases that relieve the manufacturer from liability</i>	12
2	SAFETY INFORMATION	13
2.1	FITNESS OF THE PERSONNEL	13
2.2	WARNINGS	14
	2.2.1 <i>Plates indicating instructions, obligations, dangers, prohibitions and warnings</i>	14
	2.2.2 <i>Meanings of the sign pictograms</i>	17
2.3	PROVISIONS AND PROHIBITIONS	18
2.4	TRANSPORT AND LOADING	19
2.5	CHECKS ON THE MACHINE BEFORE EACH USE	22
2.6	GENERAL SAFETY INSTRUCTIONS ON USE OF THE MACHINE	22
2.7	SAFETY INDICATIONS ON THE USE OF THE TRAVEL FUNCTION	23
2.8	SAFETY CHECKS ON THE OPERATION OF THE MACHINE, TO BE PERFORMED BEFORE USE	26
2.9	PRECAUTIONS WHEN WORK TERMINATES OR IS INTERRUPTED	27
2.10	SAFETY REGULATIONS DURING MAINTENANCE	27
2.11	PERSONAL PROTECTIVE EQUIPMENT (PPE)	28

2.12	PRECAUTIONS AND INDICATIONS OF THE BATTERY PACK	29
2.13	BATTERIES MAINTENANCE AND VERIFICATION	30
2.13.1	<i>Clothing</i>	30
2.13.2	<i>Batteries status verification</i>	30
2.13.3	<i>Replacement of individual batteries</i>	31
2.14	BATTERY STATUS MAINTENANCE	33
3	DESCRIPTION OF THE MACHINE	35
3.1	STRUCTURE OF THE EQUIPMENT	35
3.2	CONTROL STATIONS	40
3.2.1	<i>Mobile control push-button panel (console)</i>	40
3.2.2	<i>Ground control using the mobile push-button panel</i>	44
3.2.3	<i>Ground controls</i>	45
3.3	OPERATING SAFETY DEVICES	46
3.3.1	<i>Main frame inclination control device</i>	46
3.3.2	<i>Chassis tilt control device</i>	47
3.4	HYDRAULIC SYSTEM SAFETY DEVICES	48
3.4.1	<i>Hydraulic pressure limiting devices</i>	48
3.4.2	<i>Hydraulic block safety devices</i>	49
3.5	BLACKOUT SAFETY DEVICES	51
3.5.1	<i>External power source 230V or 110V</i>	51
3.5.2	<i>12V-48V system</i>	52
3.6	PLATFORM OPERATION DEVICES WHICH ARE NOT PART OF THE SAFETY SYSTEM	53
4	INSTRUCTIONS FOR USE	54
4.1	PRELIMINARY OPERATIONS	54
4.1.1	<i>Suitability of the soil</i>	54
4.2	MACHINE OPERATION	55
4.2.1	<i>Powering of the machine.</i>	55
4.2.2	<i>Travel controls</i>	57
4.2.2.1	Standard travel mode	59
4.2.2.2	Easy-Drive System (ED-S)	60
4.2.2.3	Direct-Control System (DC-S)	60
4.2.2.3.1	Dynamic Levelling ON	61
4.2.2.3.2	Dynamic Levelling OFF	61
4.2.3	<i>Machine levelling</i>	62
4.2.3.1	Automatic levelling	63

4.2.3.2	Manual levelling	63
4.2.3.3	Dynamic Levelling during travel	64
4.2.3.4	Dynamic Position System	65
4.3	POSITIONING OF THE LOAD ON THE MACHINE	66
4.4	MESSAGES AND ALARMS ON THE HOUR COUNTER	70
4.5	QUICK COUPLINGS (IF ANY)	73
4.6	STOPPING THE MACHINE	74
4.6.1	<i>Normal stop</i>	74
4.6.2	<i>Emergency stop</i>	75
5	EMERGENCY PROCEDURES	76
5.1	RECEPTION PROBLEMS WITH REMOTE CONTROL	76
5.2	TRANSPORTING THE MACHINE IN AN EMERGENCY	76
5.3	EMERGENCY MOVEMENTS FROM HYDRAULIC BLOCK	77
6	MAINTENANCE	78
6.1	GENERAL MAINTENANCE	78
6.1.1	<i>Ordinary maintenance schedule table</i>	78
6.1.2	<i>Checks before each use</i>	80
6.2	MAINTENANCE: DETAILS	81
6.2.1	<i>Checking and tightening screws, bolts, plug ring nuts</i>	81
6.2.2	<i>Visual and structural inspection</i>	82
6.2.3	<i>Damage to tubes and cables</i>	82
6.2.4	<i>Checking the hydraulic tank oil level and topping up if necessary</i>	83
6.2.5	<i>Hydraulic reservoir oil change</i>	83
6.2.6	<i>Checking the operation of the maximum pressure valves</i>	84
6.2.7	<i>Hydraulic filter replacement</i>	86
6.2.7.1	<i>Suction filters replacement</i>	87
6.2.7.2	<i>Replacing the discharge filter</i>	87
6.2.8	<i>Traction batteries (Type:Lead Crystal)</i>	89
6.2.8.1	<i>General warnings</i>	89
6.2.8.2	<i>Maintenance</i>	90
6.2.8.3	<i>Recharging</i>	91
6.2.8.4	<i>Battery storage</i>	91
6.2.9	<i>Checking the operation of the frame angle sensor</i>	93
6.2.10	<i>Verification of the chassis angle sensor function</i>	94
6.2.11	<i>Checking the differential circuit breaker</i>	95

6.2.12	Check the seal of the chassis balancing valves	96
6.2.13	Track inspection and tensioning	97
6.2.14	Checking the tracks for wear	99
6.2.15	Replacing the tracks	99
6.2.16	Track reduction gear oil level inspection	102
7	DEMOLITION	103
7.1	MACHINE LIFE	103
7.2	DECOMMISSIONING AND DEMOLITION	103
7.3	BATTERY DISPOSAL	104
8	ATTACHMENTS	105
8.1	DECLARATION OF CONFORMITY (FAC-SIMILE)	105
8.2	REPORT REGISTER	106
8.3	PROPERTY TRANSFERS	116
8.4	HYDRAULIC DIAGRAM	117
8.5	WIRING DIAGRAM	117
9	INDEX	118