

Technical sheet :

MLT 741 - 140 V+



Capacities		Metric	Imperial
Max. capacity	Q	4100 kg	9039 lbs
Max. lifting height	h3	6.9 m	22 ft 8 in
Max. outreach	r1	3.9 m	12 ft 10 in
Reach at max. height		1 m	3 ft 3 in
Breakout force with bucket		5992 daN	5992 daN
Weight and dimensions			
Unladen weight (with forks)		7755 kg	17097 lbs
Ground clearance	m4	0.42 m	1 ft 5 in
Wheelbase	y	2.81 m	9 ft 3 in
Overall length to carriage (with hitch)	l11	4.97 m	16 ft 4 in
Front overhang		1.21 m	4 ft
Overall width	b1	2.39 m	7 ft 10 in
Overall cab width	b4	0.95 m	3 ft 1 in
Overall height	h17	2.38 m	7 ft 10 in
Tilt-down angle	a5	134 °	134 °
Tilt-up angle	a4	12 °	12 °
External turning radius (over tyres)	Wa1	3.93 m	12 ft 11 in
Standard tyres		Alliance - A580 - 460/70 R24 159A8	Alliance - A580 - 460/70 R24 159A8
Drive wheels (front / rear)		2 / 2	2 / 2
Steering wheels (front / rear)		2 / 2	2 / 2
Performances			
Lifting		7 s	7 s
Lowering		7.8 s	7.8 s
Extension		6.3 s	6.3 s
Retraction		5.6 s	5.6 s
Crowd		3.2 s	3.2 s
Dump		2.8 s	2.8 s
Engine			
Engine brand		Deutz	Deutz
Engine norm		Stage V / Tier 4 Final	Stage V / Tier 4 Final
Engine model		TCD 3.6 L4	TCD 3.6 L4
Number of cylinders - Capacity of cylinders		4 - 3621 cm ³	4 - 220.97 in ³
I.C. Engine power rating / Power (kW)		136 Hp / 100 kW	136 Hp / 100 kW
Max. torque / Engine rotation		500 Nm/m @1600 tr/min	500 Nm/m @1600 tr/min
Drawbar pull (Laden)		6200 daN	6200 daN
Reversible fan		Standard	Standard
Engine cooling system		4 radiators (water + intercooler + hydraulic oil + transmission oil)	4 radiators (water + intercooler + hydraulic oil + transmission oil)
Transmission			
Transmission type		CVT	CVT
Max. travel speed (may vary according to applicable regulations)		40 km/h	24.9 mph
Differential lock		Limited slip differential on front axle	Limited slip differential on front axle
Parking brake		Automatic negative parking brake	Automatic negative parking brake
Service brake		Oil-immersed multi-discs braking on front & rear axles	Oil-immersed multi-discs braking on front & rear axles
Hydraulics			
Hydraulic pump type		Load sensing pump	Load sensing pump
Hydraulic flow - Pressure		170 l/min - 270 Bar	170 l/min - 19 PSI
Flow sharing distributor		Standard	Standard
Tank capacities			
Hydraulic oil		135 l	29.70 gal
Fuel tank		120 l	26.40 gal
Diesel Exhaust fluid (AdBlue® type)		10 l	2.20 gal
Noise and vibration			
Noise at driving position (LpA) tested following NF EN 12053 norm		72 dB(A)	72 dB(A)
Environmental noise (LwA)		105 dB(A)	105 dB(A)
Vibration to whole hand/arm		<2,50 m/s	<2,50 m/s
Miscellaneous			
Safety tractor homologation / cab homologation		Safety tractor homologation - Cab ROPS - FOPS Level 2	Safety tractor homologation - Cab ROPS - FOPS Level 2

Miscellaneous

Controls

JSM

JSM

Load chart

Rough terrain load chart (EN 1459 B) Metric

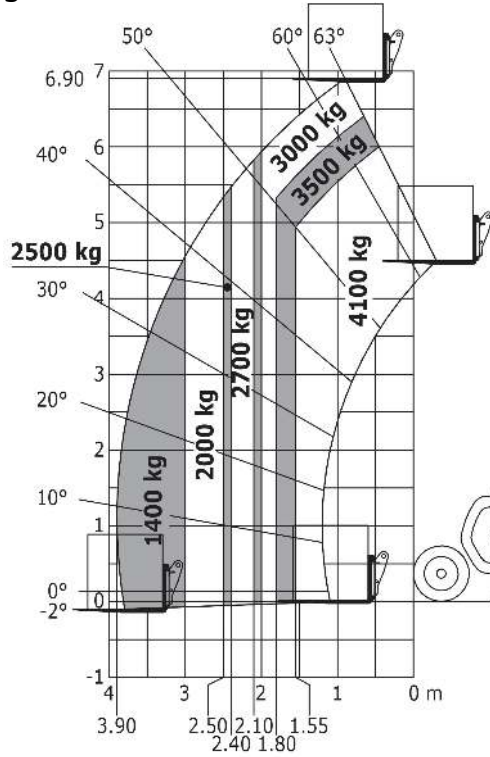

Rough terrain load chart (EN 1459 B) Imperial

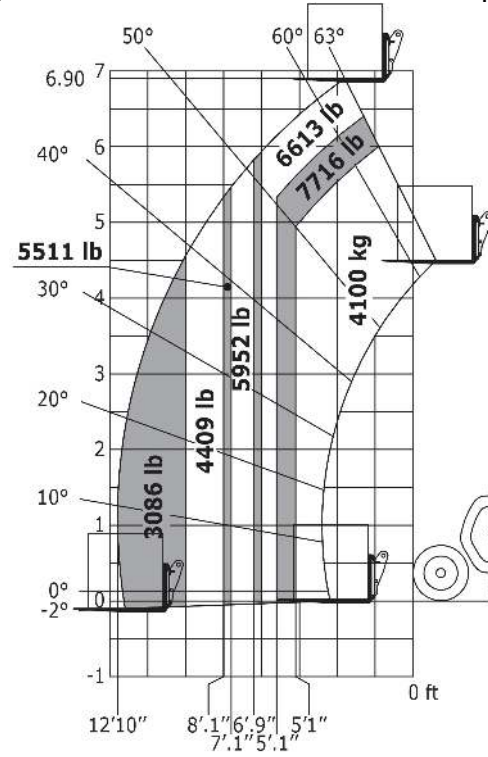

Dimensional drawing

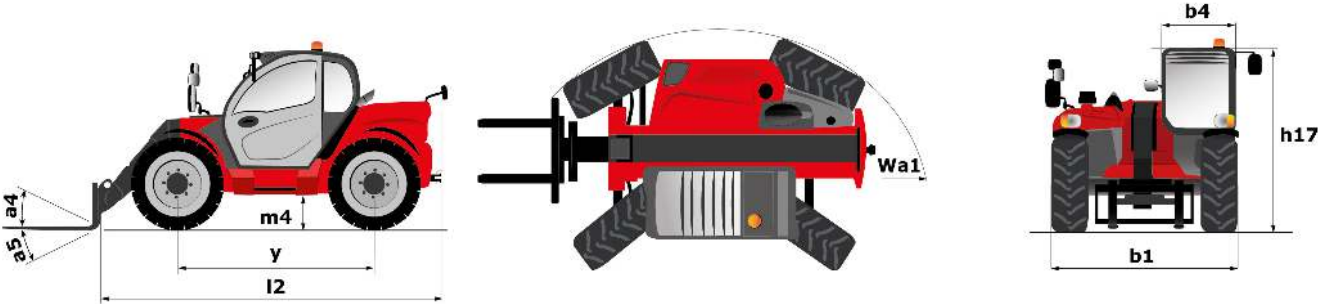



Siège Social

430 rue de l'Aubinière - 44150 Ancenis Cedex - France

Tel: +33(0)2 40 09 10 11 - Fax: +33 (0)2 40 09 10 97

www.manitou.com



This brochure describes versions and configuration options for Manitou products which may be fitted with different equipment. The equipment described in this brochure may be standard, optional or not available depending on version. Manitou reserves the right to change the specifications shown and described at any time and without prior warning. The manufacturer is not liable for the specifications given. For more information, contact your Manitou dealer. Non-contractual document. Product descriptions may differ from actual products. List of specifications is not comprehensive. The logos and visual identity of the company are the property of Manitou and may not be used without authorisation. All rights reserved. The photos and diagrams contained in this brochure are provided for information only.

MANITOU BF SA - Limited company with board of directors - Share capital: 39,668,399 euros - 857 802 508
RCS Nantes